

when
art
meets
light

TERZANI
LA LUCE PENSATA

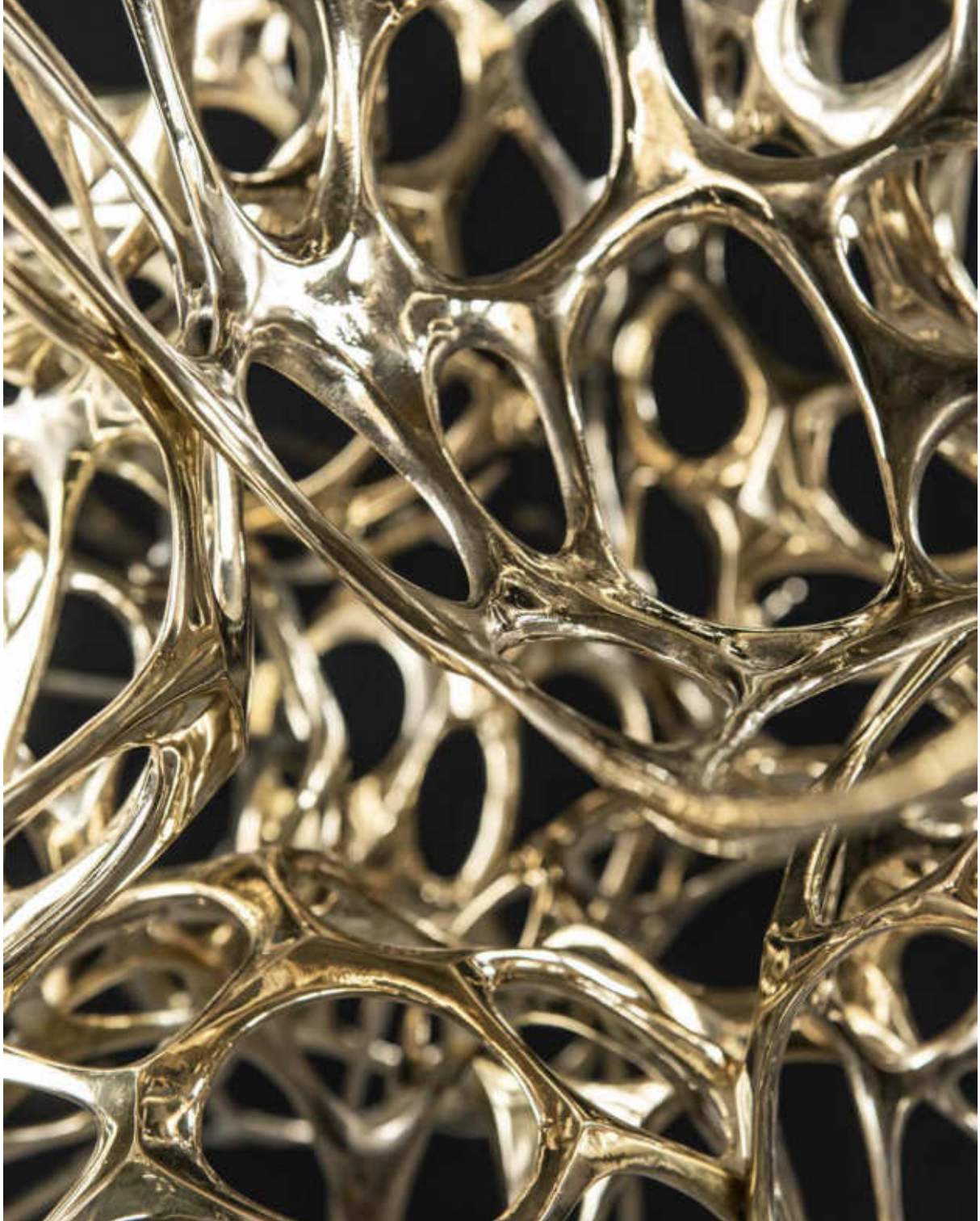

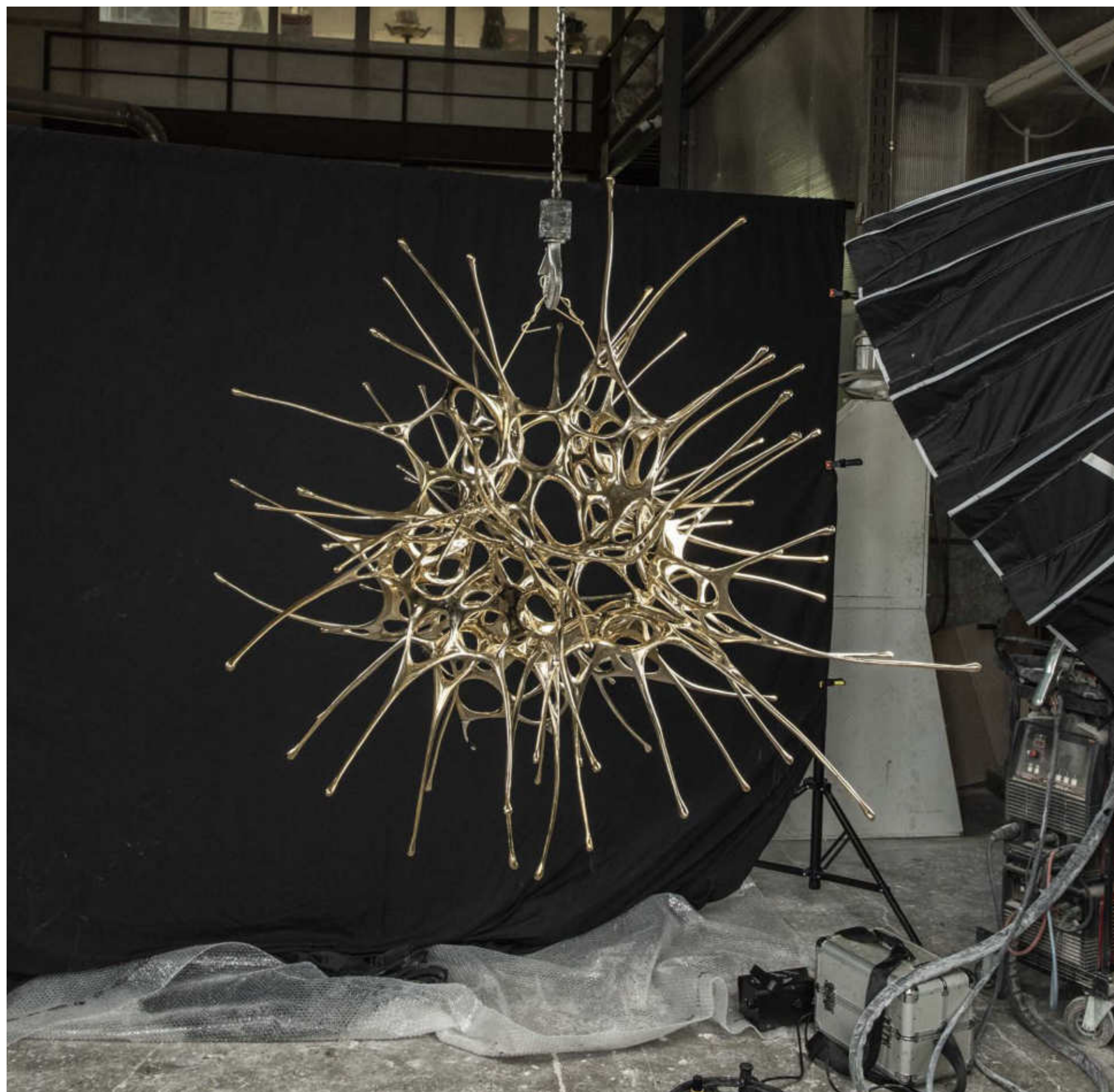

when
art
meets
light

Precious Design

Terzani's Precious Design Concept is luxury evolved. Each piece in this new lighting collection breaks the staid boundaries of traditional luxury and incorporates stunningly modern design, cutting-edge technology, artisan craftsmanship, and precious materials. The result is sculptures of light whose illumination transforms spaces through dynamic lighting and shadow effects. They create a new visual language of what luxury is, one that reflects both today's aesthetics, architecture, and design traditions yet also pushes towards the future.

index

154 Abacus
300 Angel Falls
348 Anish
084 Argent
058 Argent, mon bijou
194 Atlantis
290 Calle
280 Core
262 Doodle
024 Dragon
218 Epoque
376 Etoile
332 Frame
168 Gaia
384 Glamour
356 G.r.a.
038 Harpe
326 Iceberg
180 I Lucci Argentati
392 Magdalena
144 Manta
116 Mizu
316 Moiré
366 Orten'zia
306 Oscar
342 Pug
254 Soscik
052 Stanley
240 Stream
228 Volver



crea-
tivity



sculp-
tural

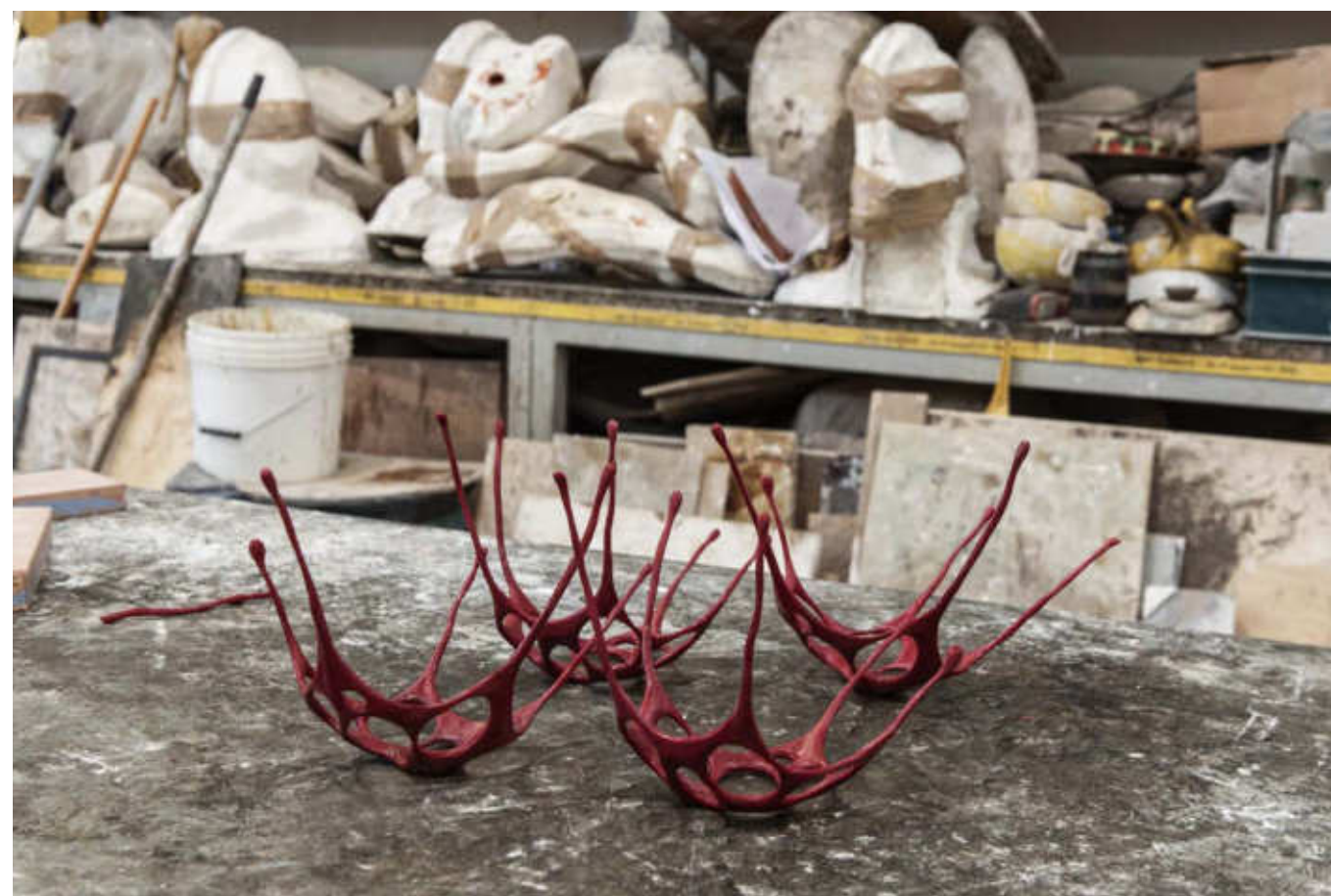



be- spoke

Work with the Terzani design team to bring to life your idea. From simple modifications to more complex design changes.





ele- gan- ce





hand-
made





herit-
age





e-
motion





contem-
porary



Dragon, art's heartbeat.

Dragon represents a new chapter for Terzani: the first piece designed as a standalone brass sculpture, cast at a historic foundry in Tuscany. At Terzani, our creative process benefits from the dialogue created between our history, our creative partners, and our innovative spirit. When creating Dragon, we found that the most powerful expression was not as a lighting design but as a sculptural work of art, one that elevates the artist and harnesses our creative expertise. In Chinese mythology, the dragon is a nature deity central to creation tales. Thus, it makes sense that the latest from designer Dodo Arslan tapped into this powerful, ancient symbolism for his newest creation. In a dramatic rethinking of how rooms are experienced, Dragon is a sculpture designed to not only grab attention but also change how a space is considered. An explosion of liquid metal, tamed by Terzani's Tuscan master craftsmen, Dragon reflects the power of the fires that shaped it and speaks to the connection between earth and water. This handcrafted piece embodies the cyclical dance of the elements while evoking a cosmic harmony. Its presence unites not only a space but those who inhabit it. Each Dragon is a unique, fully customizable, and numbered sculpture. While it imparts the feeling of the natural, organic form, it is a painstakingly crafted piece of art and an ode to the fusion between the creative force of man and nature. Design Dodo Arslan.

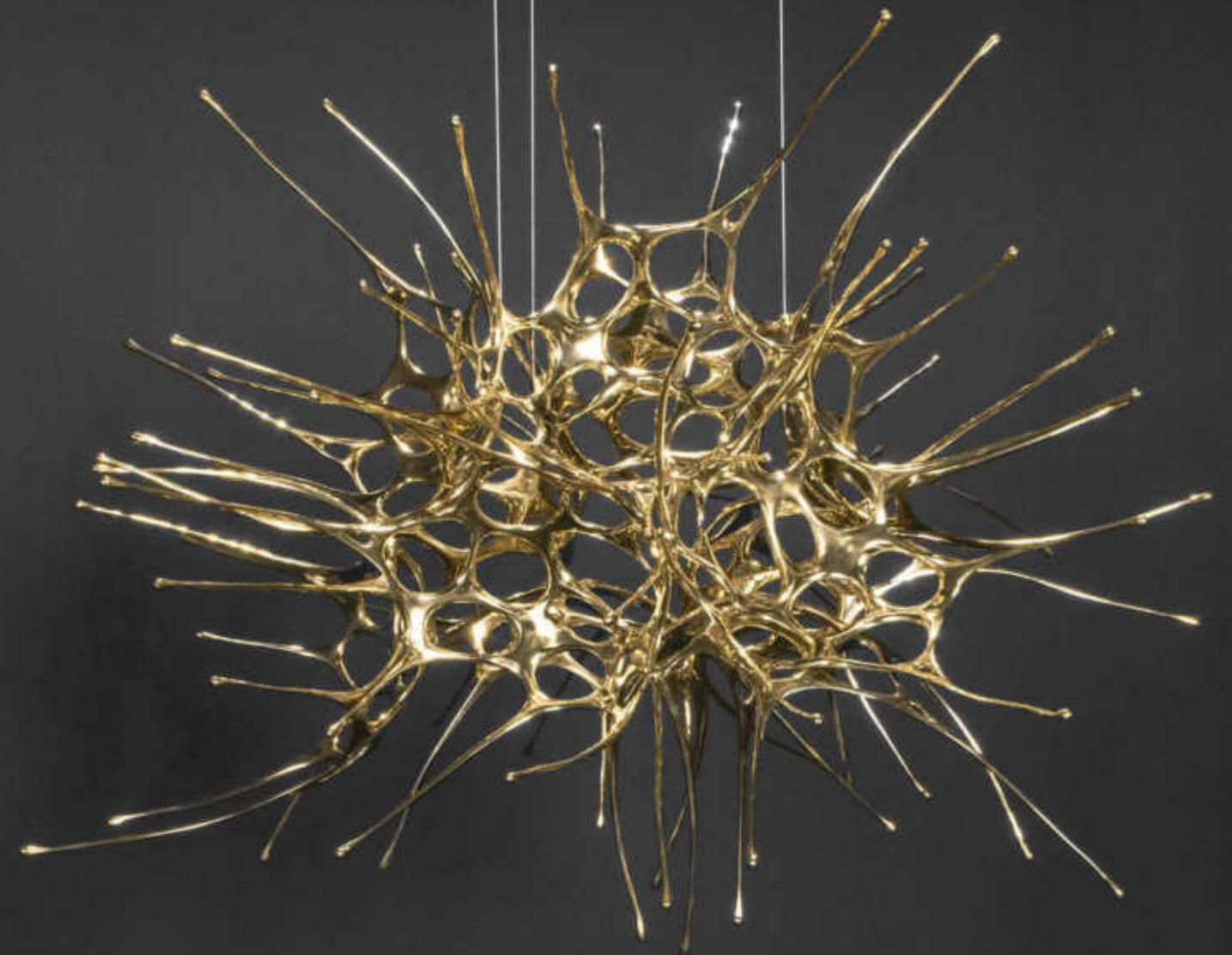











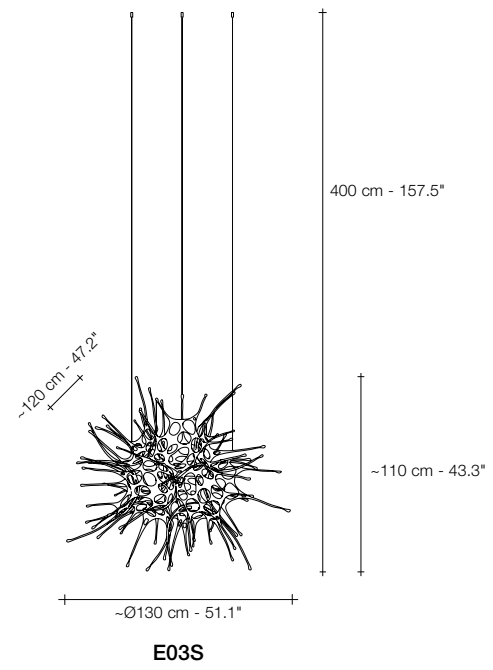
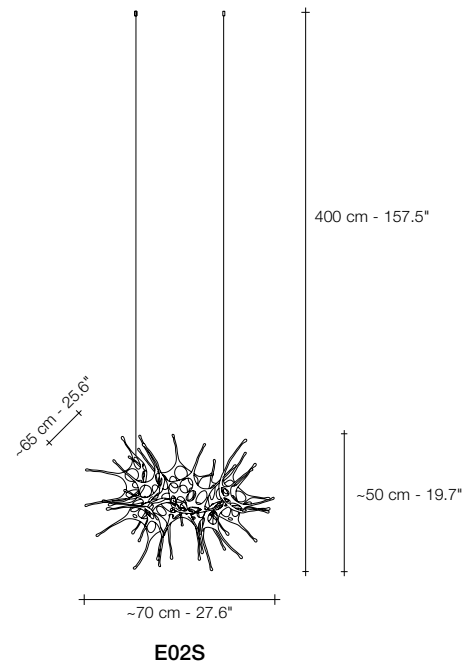

POLISHED BRASS

Dragon is designed as a standalone sculpture. You may choose to illuminate it with architectural lighting, which can be sourced independently or purchased from Terzani. Please refer to our spec sheet for light source options or contact our team for more details.

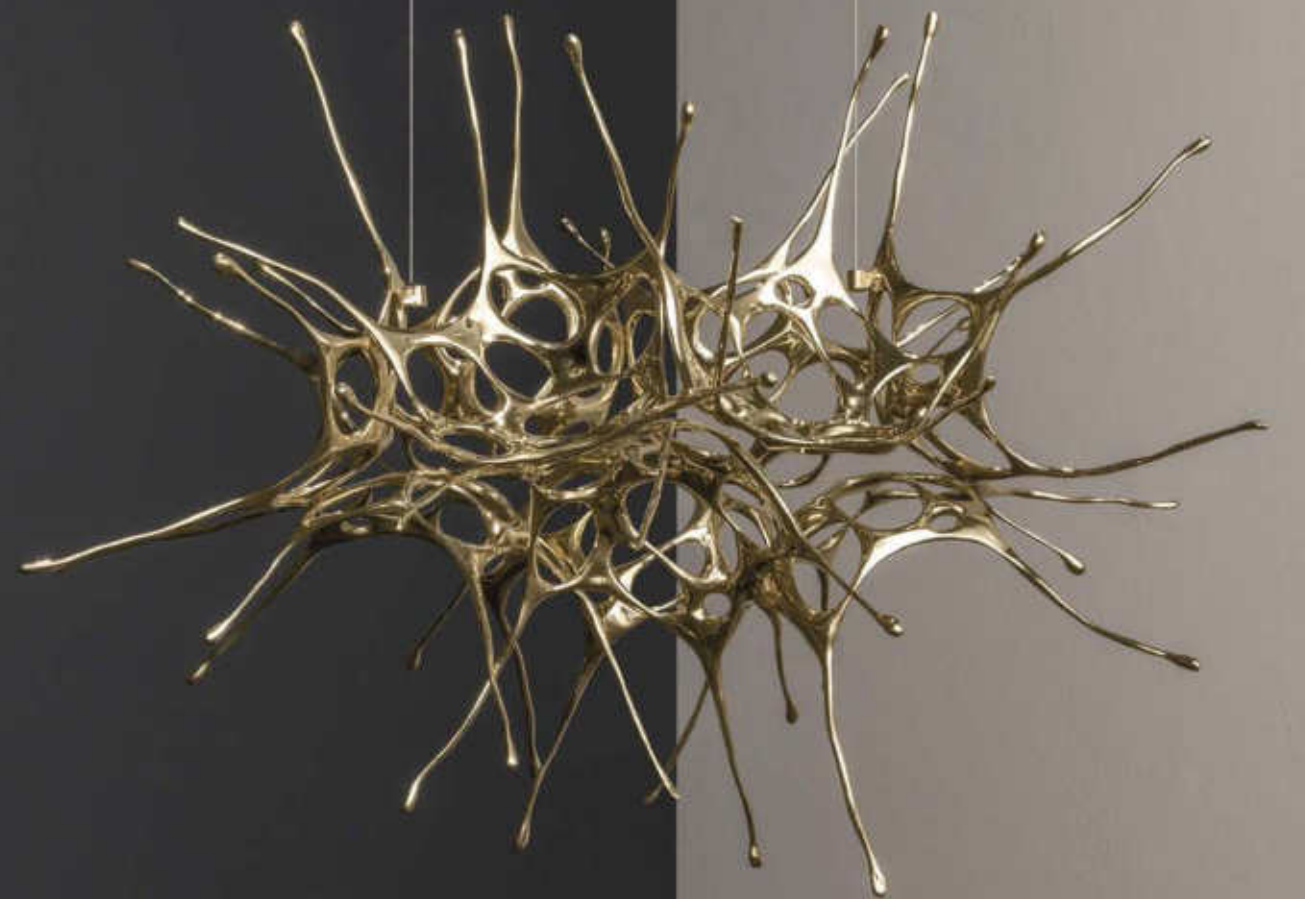

Harpe, the sound of light.

The new Harpe collection comes from the childhood memory of its designer, Christian Lava. Like most children, he would look up into the sky and visualize shapes in the clouds as they passed by. His active imagination would run wild with the fantastic things that emerged. One day, Christian looked up into the sky only to see a gray, leaden blanket of clouds. However, against this blank canvas, a break in the sky appeared, and bright sunlight came streaming down in rays reminiscent of a harp. It's the memory of this divine instrument that inspired our latest pendant, Harpe. Made of metal, Harpe is available in three different shapes and sizes, and can be assembled in infinite combinations. Design Christian Lava.





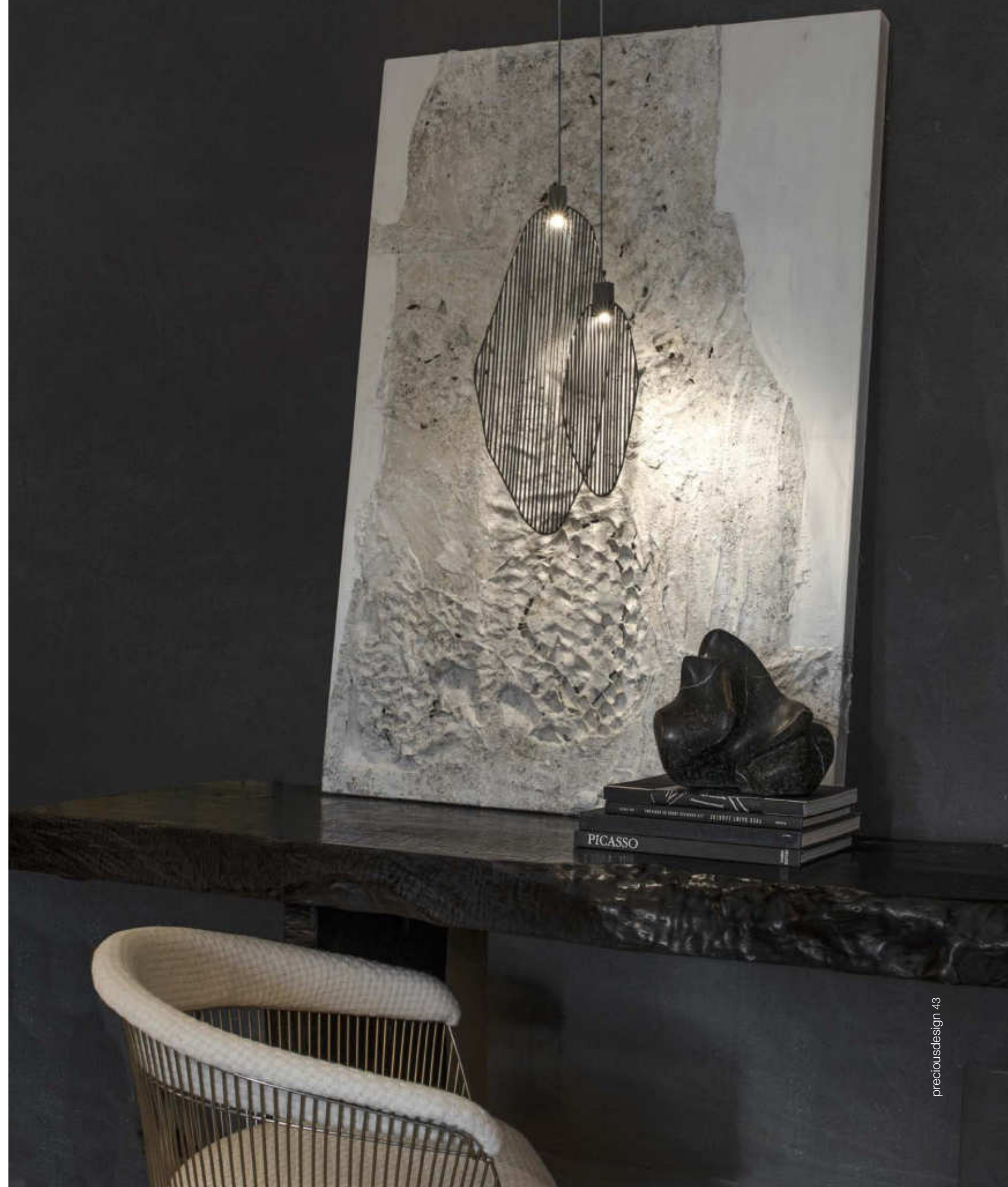







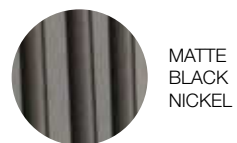
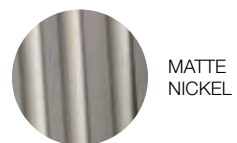
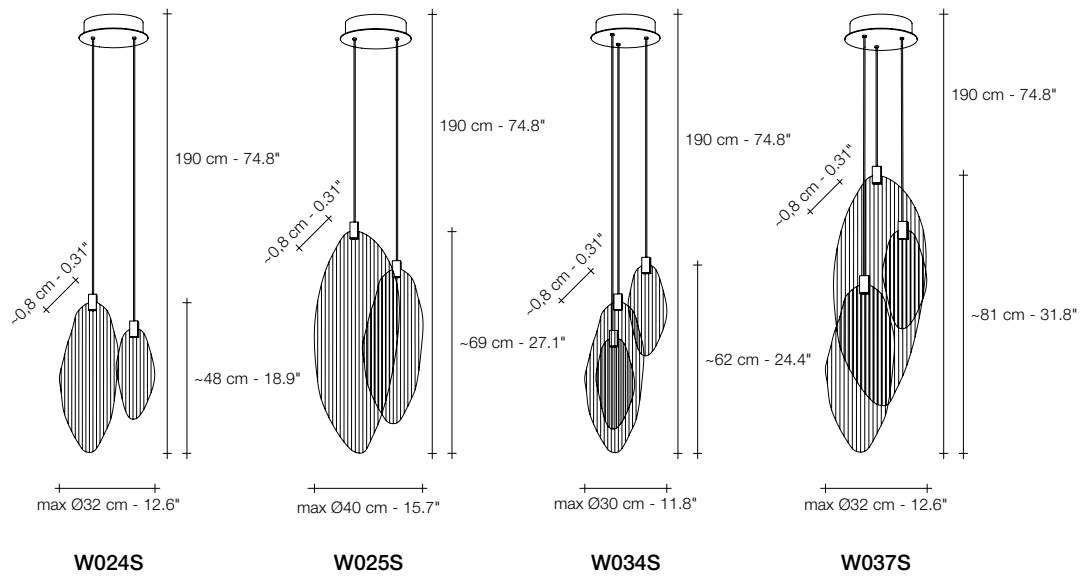
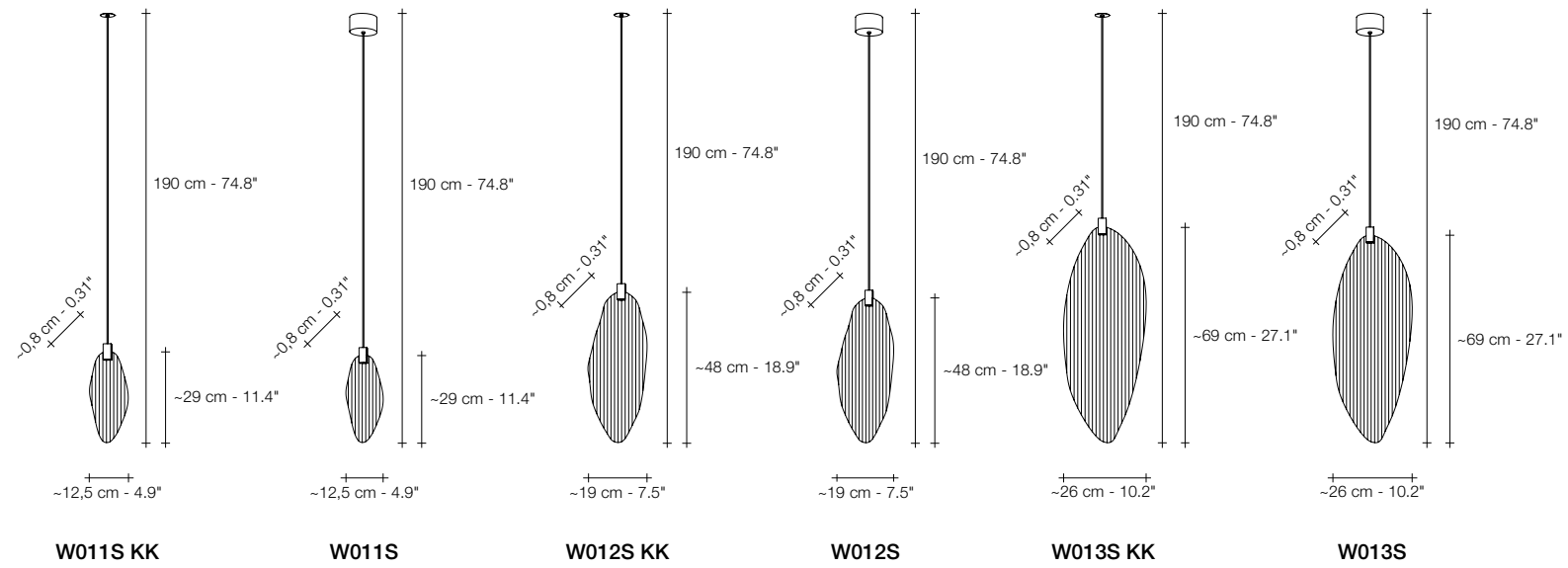

LIGHT SOURCE		W011S KK	W011S	W012S KK	W012S	W013S KK	W013S	W024S	W025S	W034S	W037S
120V 230V	Integrated LED module 3000K	2,1W 237 lm	2,1W 237 lm	2,1W 237 lm	2,1W 237 lm	2,1W 237 lm	2,1W 237 lm	2x2,1W 474 lm	2x2,1W 474 lm	3x2,1W 711 lm	3x2,1W 711 lm
	Dimmable	IGBT TRIAC 0/1-10V PUSH DALI	IGBT TRIAC	IGBT TRIAC 0/1-10V PUSH DALI	IGBT TRIAC	IGBT TRIAC 0/1-10V PUSH DALI	IGBT TRIAC	IGBT TRIAC	IGBT TRIAC	IGBT TRIAC	IGBT TRIAC

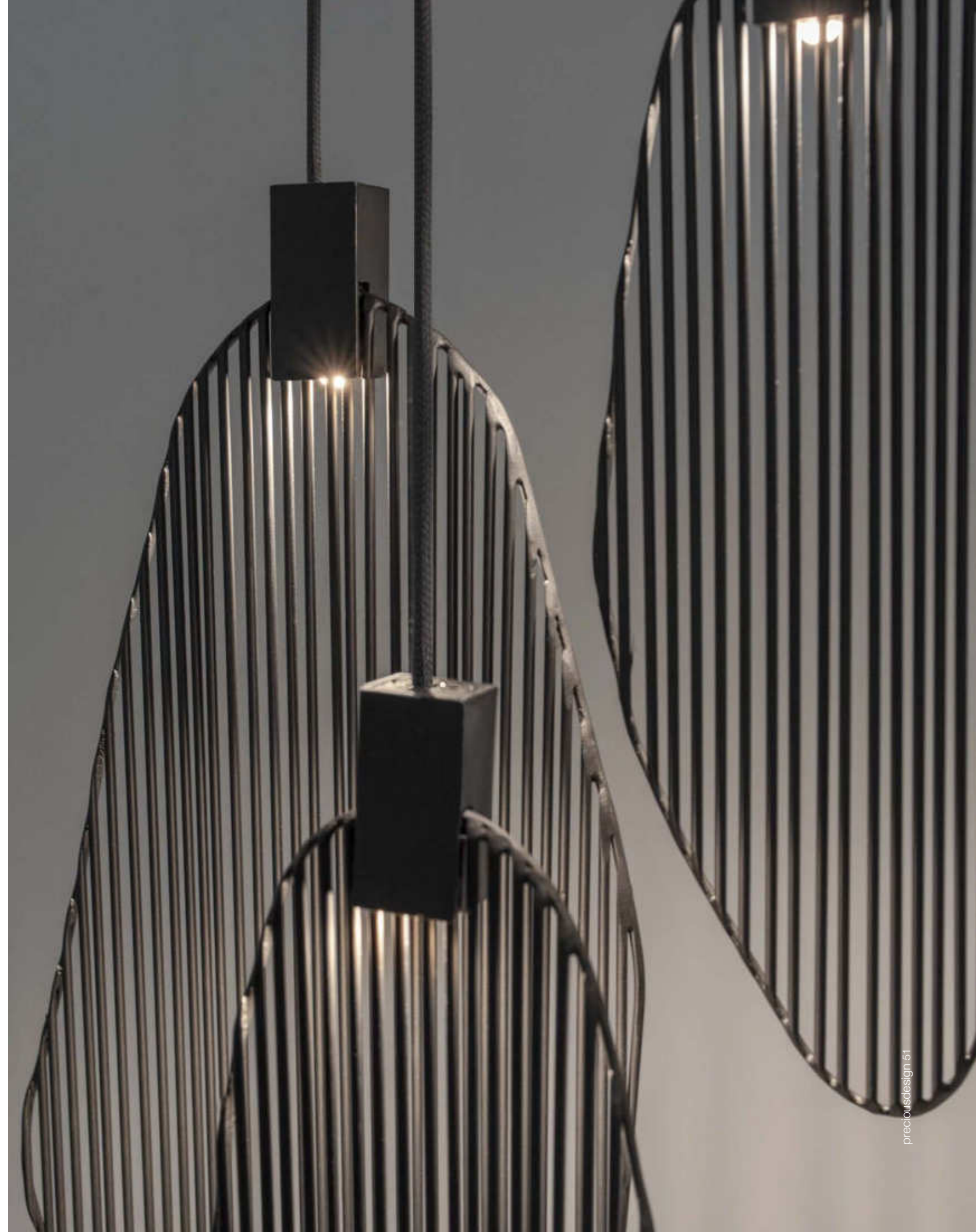

Capturing the mystery, power, and wonder of the stars, this new floor lamp from Dodo Arslan conjures the natural beauty of space and mankind's fascination with the heavens. Blades of crystalline light travel through a field of stars, creating a deep, rich, and nuanced viewing experience. Stanley's multiple perspectives create a cosmic vision with infinite depth.

Stanley, journey beyond the stars.

An homage to the genius of Stanley Kubrick and his masterpiece, 2001: A Space Odyssey, Arslan's design aims to open doors to new galaxies. By recreating the mysteries of our universe, Stanley captures the sense of awe that continues to compel artists, scientists, and dreamers to look to the sky for answers and inspiration. Staying in accordance with the vibrancy of space, Stanley offers a series of chromatic variations that can be customized, creating a unique, tonal experience. Design Dodo Arslan.





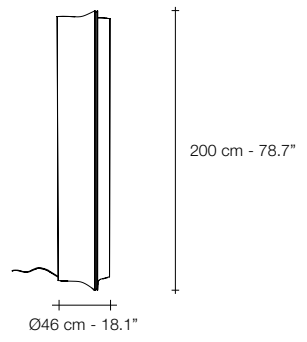

C06P



BRUSHED
STAINLESS STEEL

LIGHT SOURCE

- 120V | 230V
- Top:
Integrated replaceable LED | 21W | 2875 lm
 - +
 - Edges:
Integrated replaceable LED | 3x39W | 12875 lm
 - Total 138W | 15750 lm | 3000K | CRI>90

Casambi technology | Xpress wireless switch
Each light source can be dimmed independently or in programmable groups.
Light sources are replaceable.



When our Argent collection debuted a decade ago, we knew we had created something special. Working with designer Dodo Arslan, our melding of Italian craftsmanship with contemporary design redefined the industry. Ten years later, we are building upon the success of this original collection with a new chapter: Argent, Mon Bijou.

Argent, mon bijou.

Again, partnering with Dodo Arslan, we asked ourselves: what have we learned from our evolution as designers and craftsmen? How can we make this new collection as daring, beautiful, and innovative as its predecessor? Our answer is a new series of pendant lights and table lamps that draw inspiration from across design: from the fashion of Paco Rabanne, the work of Verner Panton, the mirrored art of Julio Le Parc, and the natural beauty of the Italian seaside. The result is a lamp reminiscent of a shimmering cloud casting brilliant, ethereal light across the room. Handmade by our craftsmen in stainless steel, each piece is both unique and a modular element of an extremely flexible system. Our goal is to give architects and designers the freedom to express their visions without limits, adapt to any environment, and add a touch of magic. Design Dodo Arslan.

























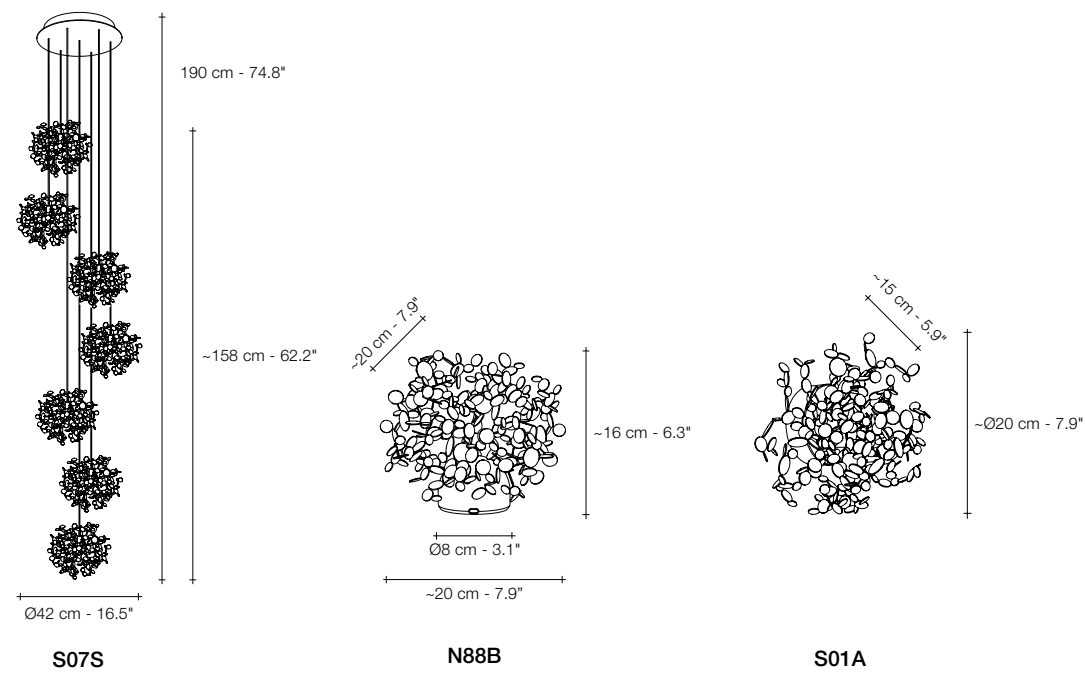
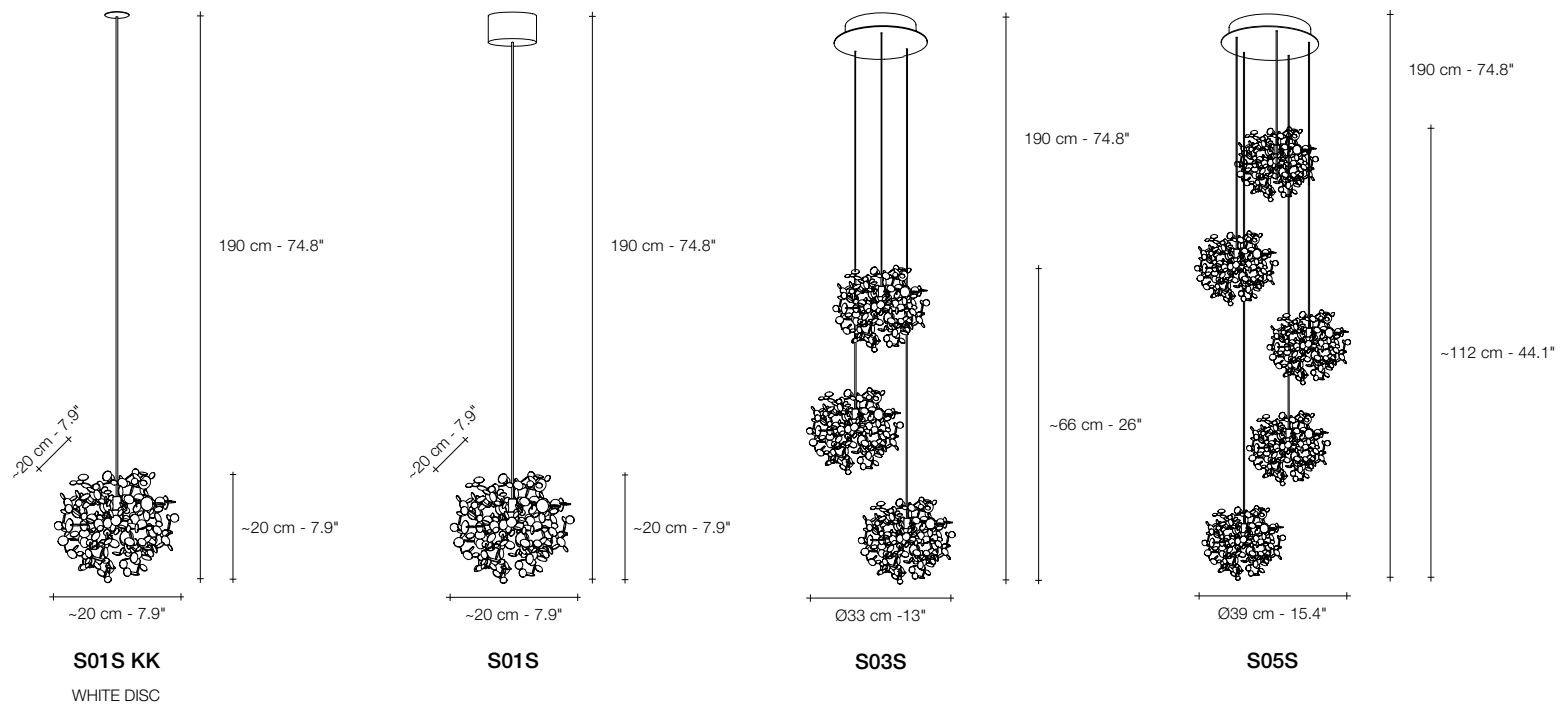

STAINLESS
STEEL



GOLD
PLATED |
PVD COATING



ROSE GOLD
PLATED |
PVD COATING



CHAMPAGNE
PLATED |
PVD COATING

	S01S KK	S01S	S03S	S05S	S07S	N88B	S01A
LIGHT SOURCE	Replaceable LED module	1,5W	1,5W	3x1,5W	5x1,5W	7x1,5W	1,4W
	3000K	174 lm	174 lm	522 lm	870 lm	1218 lm	max 210 lm
	2700K	164 lm	164 lm	492 lm	820 lm	1148 lm	-
Dimmable	IGBT TRIAC 0/1-10V PUSH/DAI	IGBT TRIAC	IGBT TRIAC	IGBT TRIAC	IGBT TRIAC	integrated 4 step dimmer	0/1-10V PUSH



Argent, a precious cloud.

With this light, designer Dodo Arslan creates a shimmering cloud. Argent consists of metal discs that have been meticulously shaped by Terzani craftsmen into clusters. Once lit, the multiple angled surfaces of the discs emanate a soft, shimmering glow. Argent is available in stainless steel, gold plated, rose gold plated, and champagne plated finishes. Black nickel plated is available on request. Design Dodo Arslan.



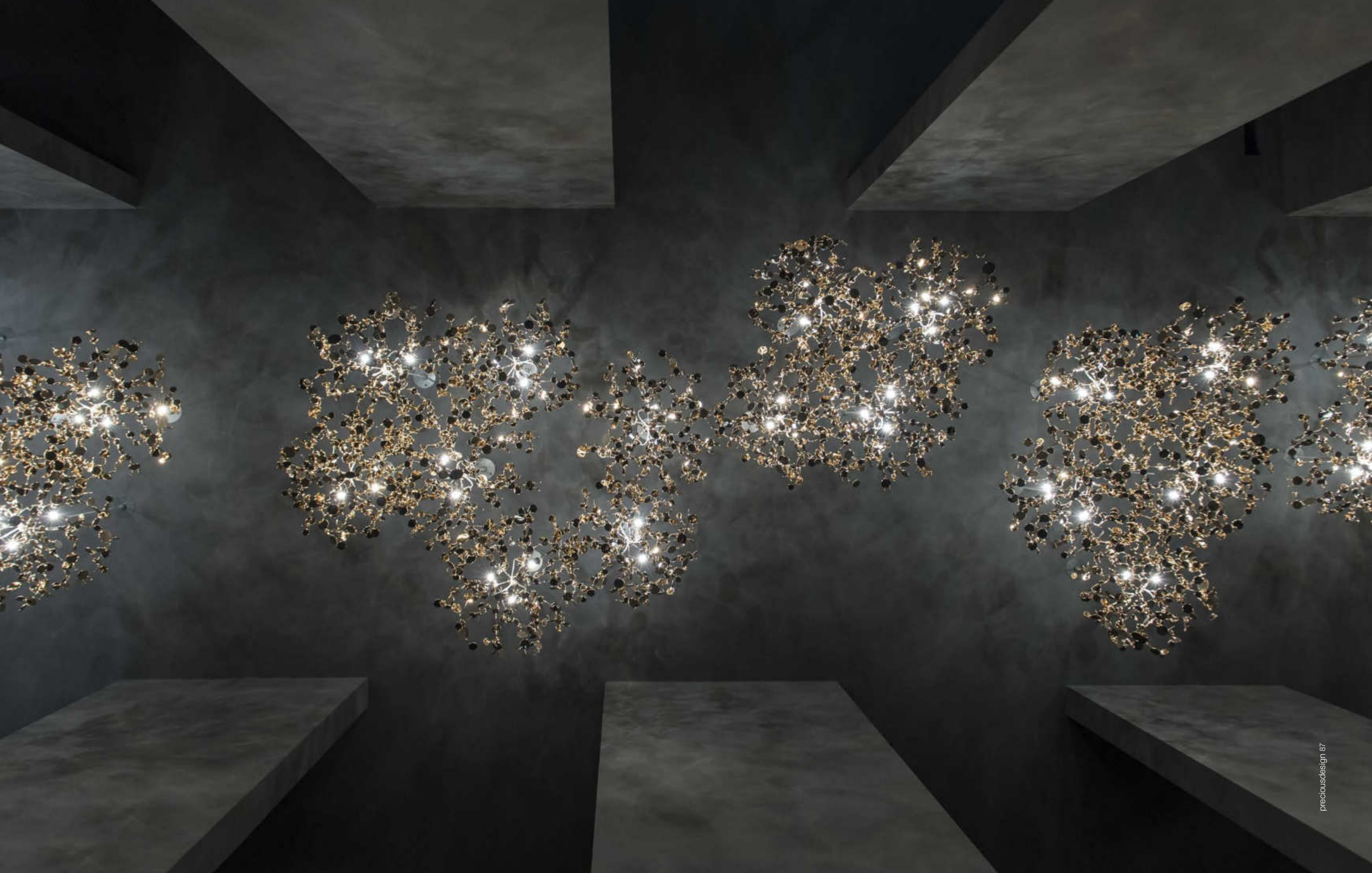





















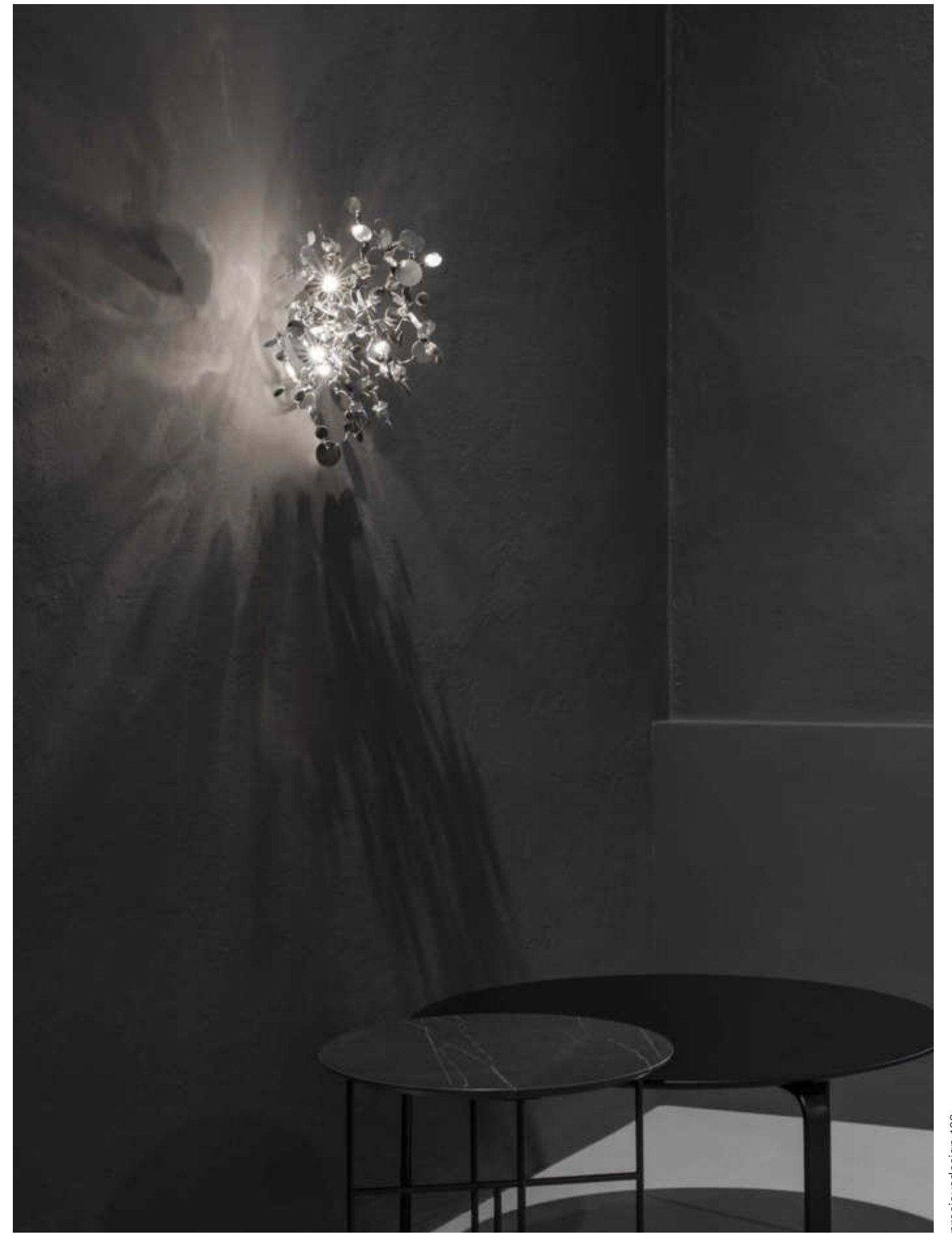





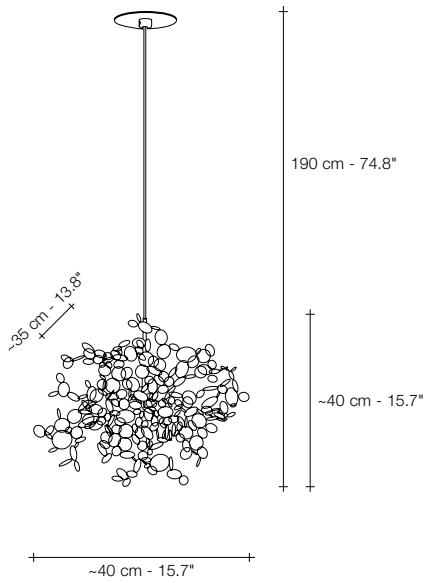

N90S KK
WHITE DISC

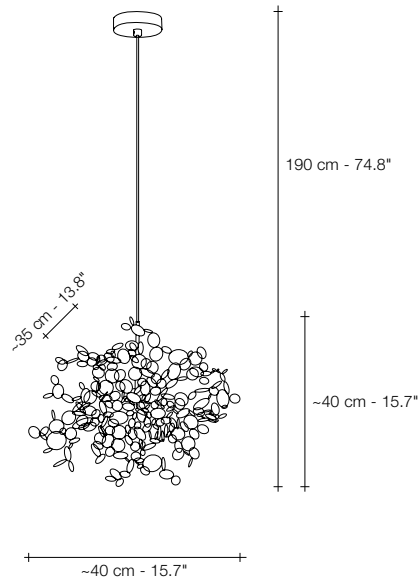

N90S

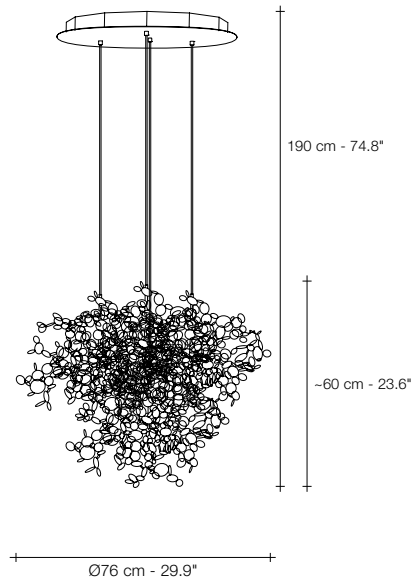

N91S

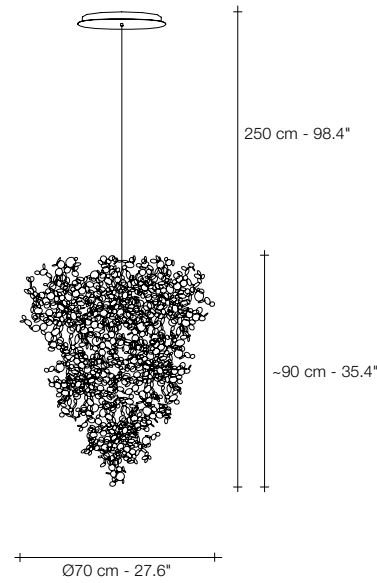

N93S

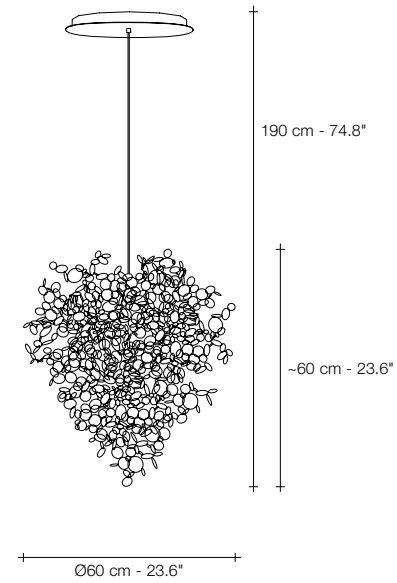

N95S

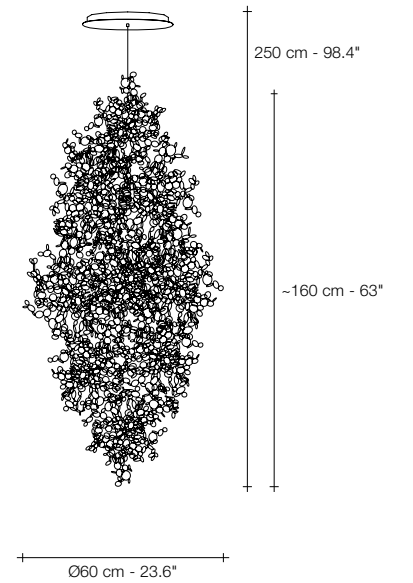

N94S

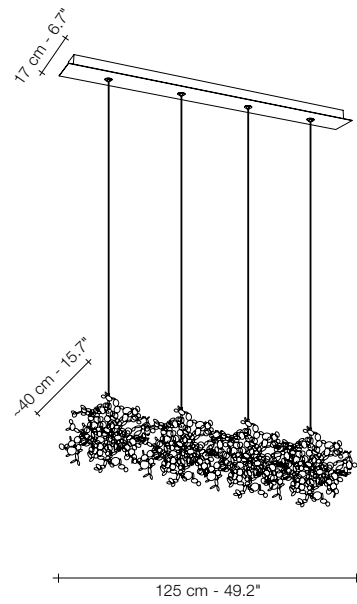

N92S

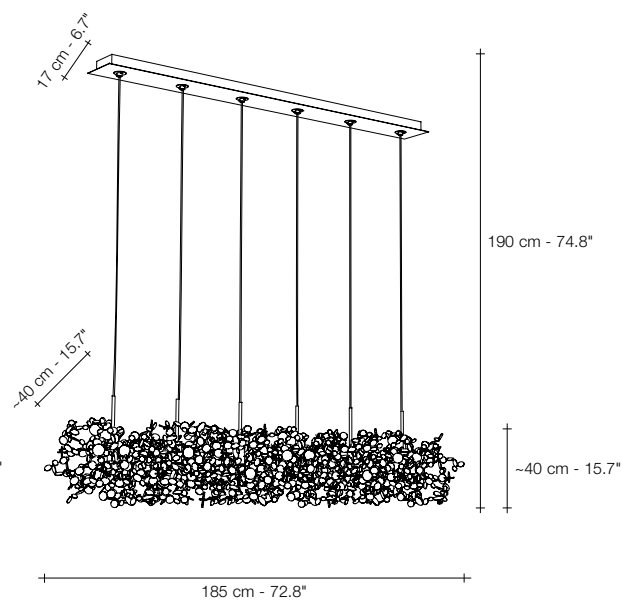

N89S

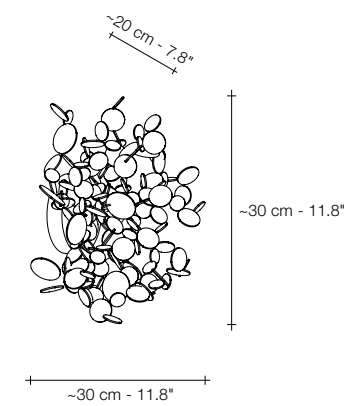

N97A

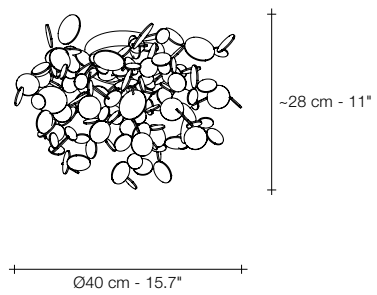

N99L

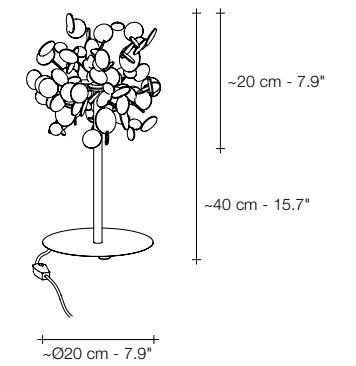

N98B

N/A in North America



STAINLESS STEEL



GOLD PLATED



ROSE GOLD PLATED



CHAMPAGNE PLATED

LIGHT SOURCE OPTIONS		N90S KK	N90S	N91S	N92S	N89S	N97A	N99L	N98B	LIGHT SOURCE			
230V	 G4 HALOGEN G4 LED Dimmable	3x20W	3x20W	12x20W	12x20W	18x20W	3x20W	3x20W	-	Replaceable LED module 3000K 2700K Dimmable	N95S	N93S	N94S
		3x2W	3x2W	12x2W	12x2W	18x2W	3x2W	3x2W	3x2W		3x2W	6x2.1W	12x2.1W
120V	 G4 XENON G4 LED Dimmable	0/1-10V 100KΩ PUSH DALI	IGBT TRIAC DALI	IGBT 0/1-10V 100KΩ PUSH DALI	IGBT 0/1-10V 100KΩ PUSH DALI	IGBT 0/1-10V 100KΩ PUSH DALI	IGBT TRIAC DALI	IGBT TRIAC DALI	no	Replaceable LED module 3000K 2700K Dimmable	1-10V PUSH	0/1-10V PUSH/DALI	0/1-10V PUSH/DALI
		3x20W 3x2W	3x20W 3x2W	12x20W 12x2W	12x20W 12x2W	18x20W 18x2W	3x20W 3x2W	3x20W 3x2W	-		-	6x2.1W	12x2.1W
		ELV	ELV	ELV	ELV	ELV	ELV	ELV	-				

Argent N93S, N94S, N95S available with integrated LED 3000K or 2700K. Different dimming options on request.

Mizu, flowing light.

Inspired by the tranquil and mesmerizing light refractions created by water, Mizu is a customizable pendant light from Terzani. Like water droplets, no two Mizu are alike; each crystal shape is unique and meticulously handmade. Using only the clearest crystal, Mizu perfectly emulates water's refraction of light, casting amazing patterns around the room, reminiscent of flowing water. Available in clear, silver dust, gold, cognac, and champagne finish. Design Nicolas Terzani.













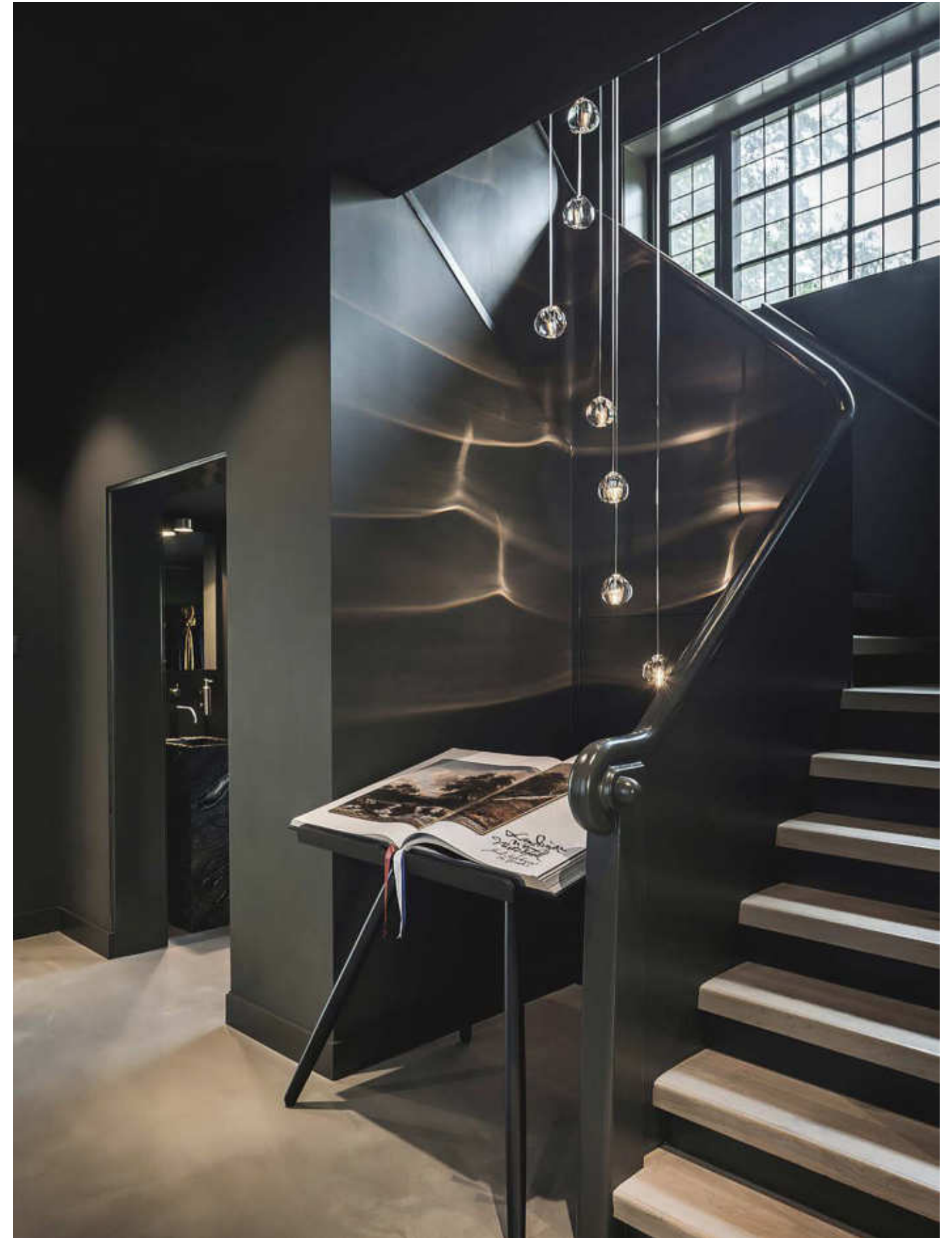

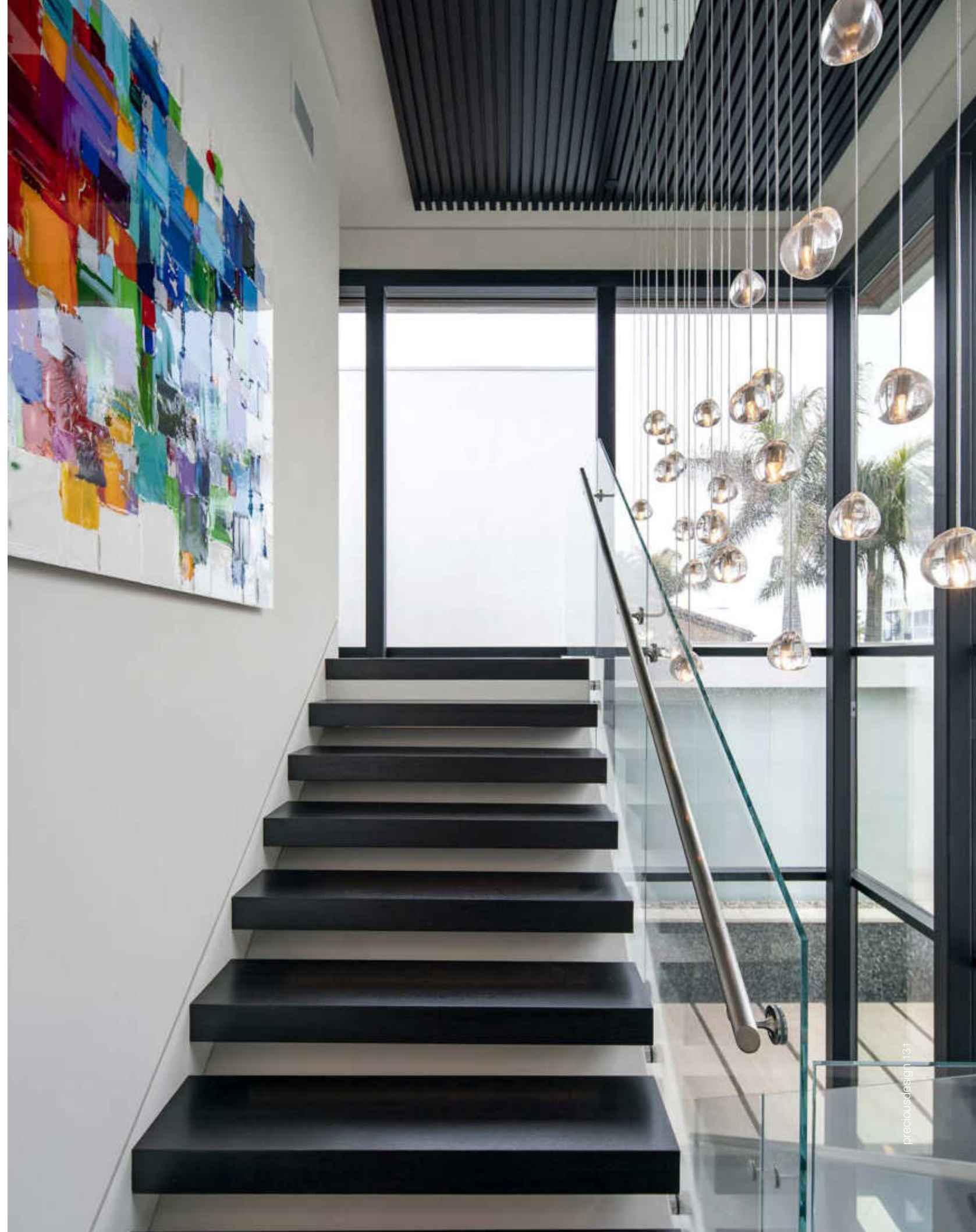











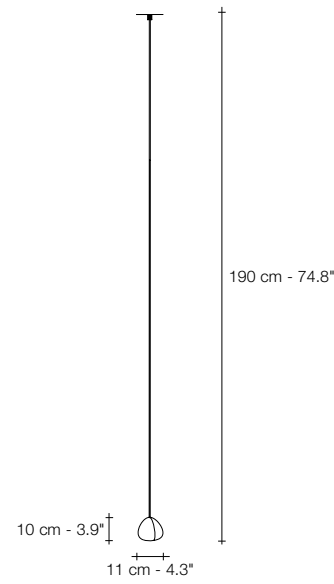

R01S KK
WHITE DISC

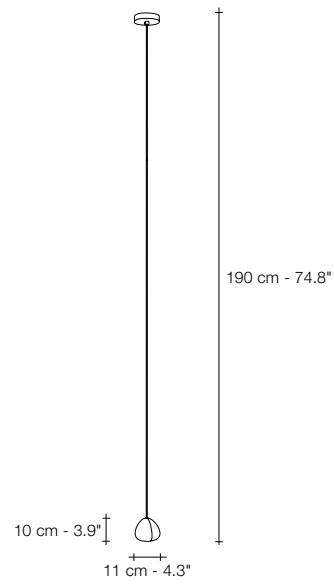

R01S

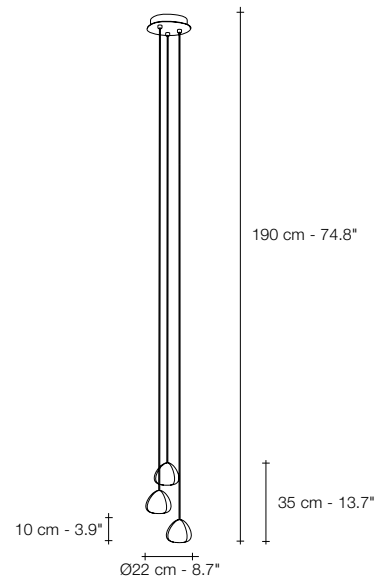

R03S

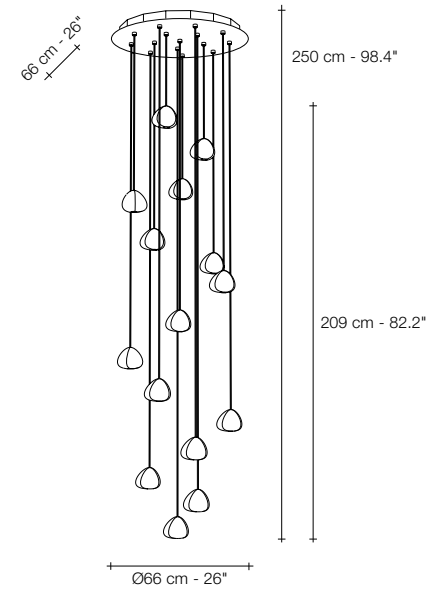

R15ST

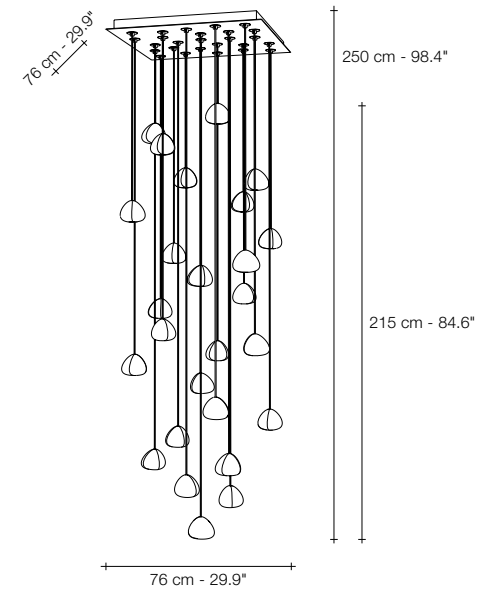

R26SQ

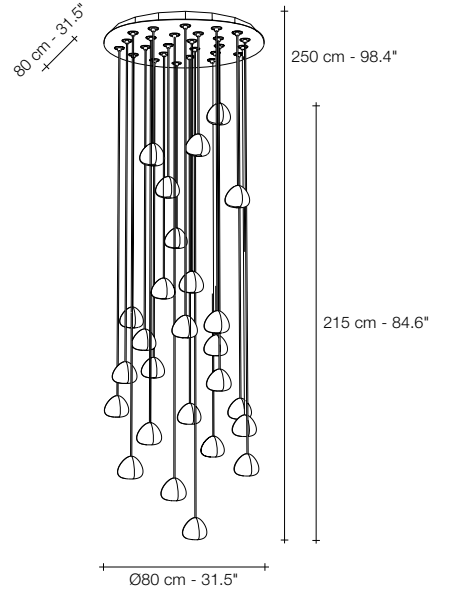

R26ST

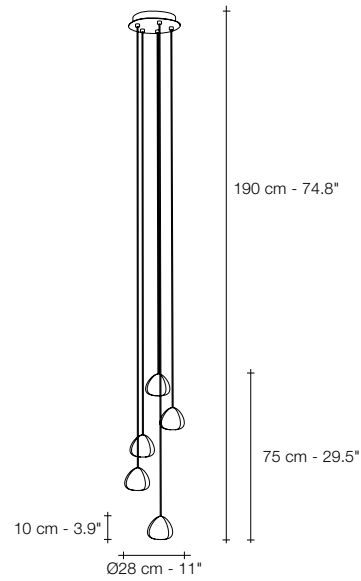

R05S

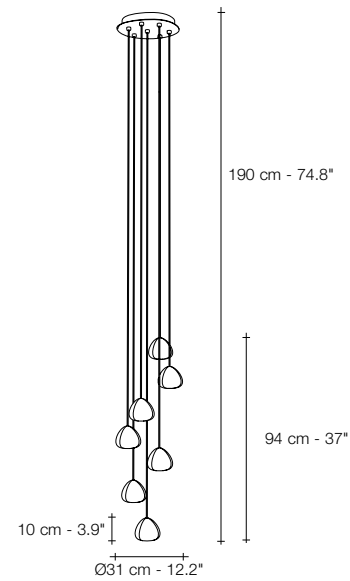

R07S

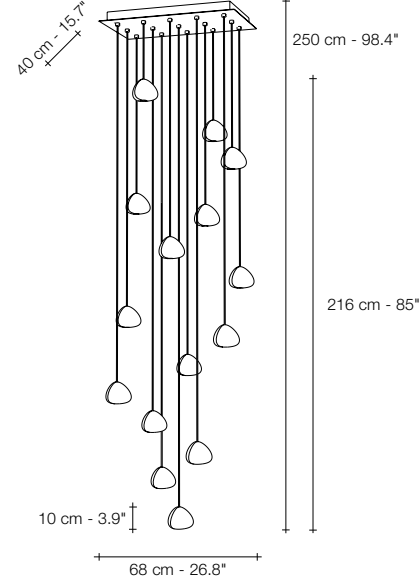

R15SR



CLEAR
CRYSTAL



CHAMPAGNE
CRYSTAL



COGNAC
CRYSTAL



SILVER
DUST
CRYSTAL



GOLD
CRYSTAL

	R01S KK	R01S	R03S	R05S	R07S	R15SR	R15ST	R26SQ	R26ST	
230V	G4 HALOGEN	10W	10W	3x10W	5x10W	7x10W	15x10W	15x10W	26x10W	26x10W
	G4 LED	2W	2W	3x2W	5x2W	7x2W	15x2W	15x2W	26x2W	26x2W
230V	Replaceable LED module	1,5W	1,5W	3x1,5W	5x1,5W	7x1,5W	15x1,5W	15x1,5W	26x1,5W	26x1,5W
		174 lm	174 lm	522 lm	870 lm	1148 lm	2610 lm	2610 lm	4524 lm	4524 lm
230V		2700K	2700K	492 lm	820 lm	1218 lm	2460 lm	2460 lm	4264 lm	4264 lm
	Dimmable	IGBT 100KΩ 0/1-10V PUSH/DALI	IGBT TRIAC DALI	IGBT 1-10V PUSH DALI	IGBT 0/1-10V PWM PUSH/DALI	IGBT 0/1-10V PWM PUSH/DALI	IGBT 0/1-10V PWM PUSH/DALI	IGBT 0/1-10V PWM PUSH/DALI	IGBT 0/1-10V PWM PUSH/DALI	IGBT 0/1-10V PWM PUSH/DALI
120V	G4 XENON	10W	10W	3x10W	5x10W	7x10W	15x10W	15x10W	26x10W	26x10W
	G4 LED	2W	2W	3x2W	5x2W	7x2W	15x2W	15x2W	26x2W	26x2W
	Dimmable	ELV	ELV	ELV	ELV	ELV	ELV	ELV	ELV	ELV

Mizu available with integrated LED 3000K or 2700K. Different dimming options on request

Manta, shimmering waves.

Manta was created featuring sinuous, undulating lines. The result is soft waves of crystal light reminiscent of being underwater. The innovative Manta is made of crystal, with a dimmable integrated led lamp focused on maximizing the crystal's reflection. Manta's organic form is available in two sizes and can be installed in numerous, customizable arrangements. Design Dodo Arslan & Nicolas Terzani.









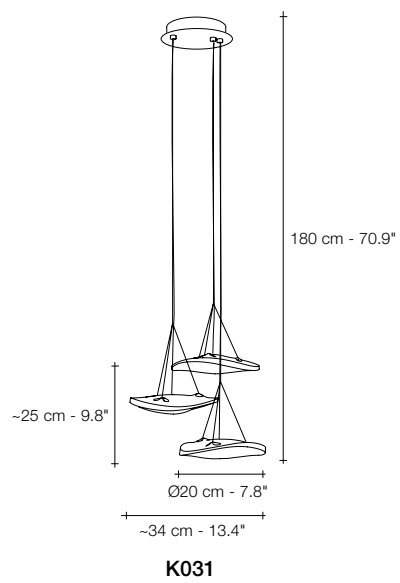
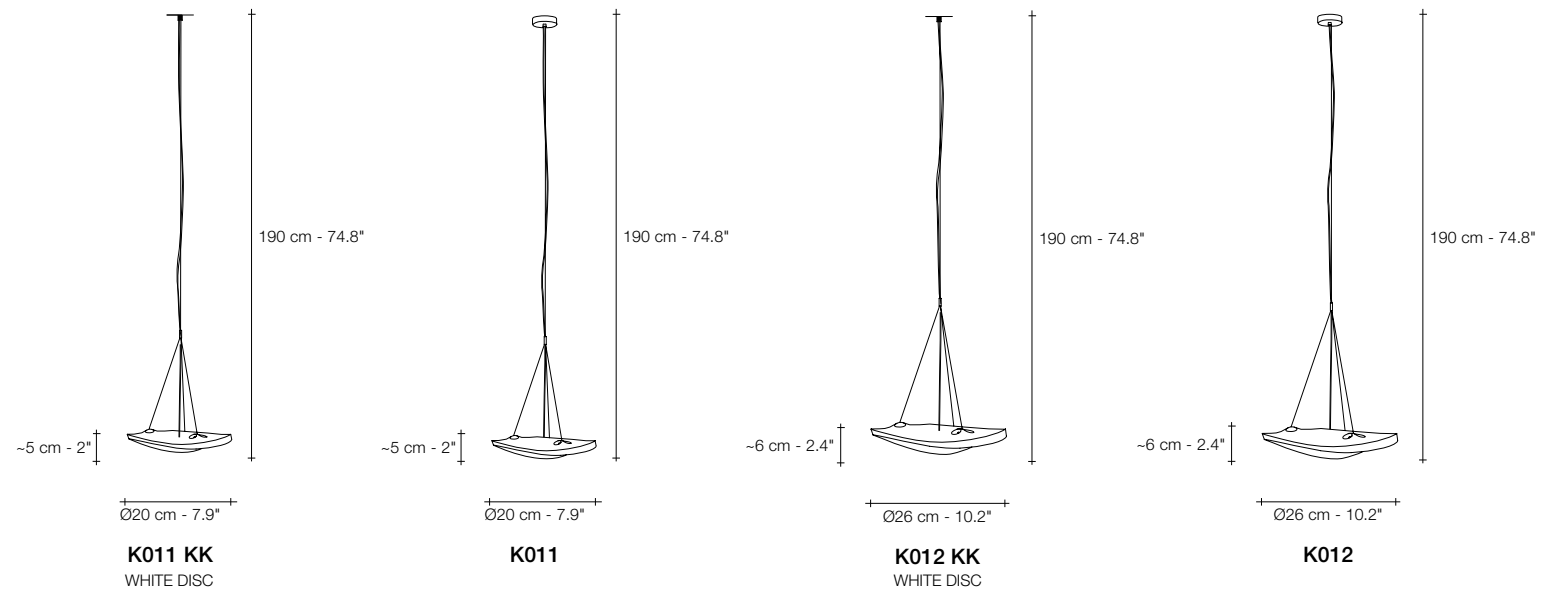

CLEAR CRYSTAL

	LIGHT SOURCE	K011 KK	K011	K012 KK	K012	K031
230V	Replaceable LED module	1,5W	1,5W	1,5W	1,5W	3x1,5W
	3000K	135 lm	135 lm	135 lm	135 lm	405 lm
	2700K	115 lm	115 lm	115 lm	115 lm	345 lm
	Dimmable	0/1-10V PUSH/DALI	PUSH/DALI	0/1-10V PUSH/DALI	PUSH/DALI	1-10V PUSH/DALI
120V	Replaceable LED module	1,5W	1,5W	1,5W	1,5W	3x1,5W
	3000K	135 lm	135 lm	135 lm	135 lm	405 lm
	2700K	115 lm	115 lm	115 lm	115 lm	345 lm
	Dimmable	0/1-10V PUSH/DALI	no	0/1-10V PUSH/DALI	no	1-10V PUSH

Manta available with integrated LED 3000K or 2700K. Different dimming options on request.



Used for centuries as a tool to both teach and communicate mathematics, the abacus was found in one form or another across the ancient world. At Terzani, we saw the beauty in the abacus' mathematical purity and clean, functional design.

Abacus, multiplying luminescence.

In the hands of Terzani's craftsmen, we've turned this inspiration into a new collection of modular pendant lamps whose flexibility allows for complex and beautiful configurations. Each module, or strand, of Abacus is made of a custom set of round, hand-blown opal glass that emits a soft and uniform light. And, as the original abacus was used to calculate everything from simple addition to complex formulas, we've retained the same scalability. Due to its customization, our Abacus light is just as suitable in a home as in a commercial space, and its almost infinite configurations ensure you always find the right solution. Design Draw.







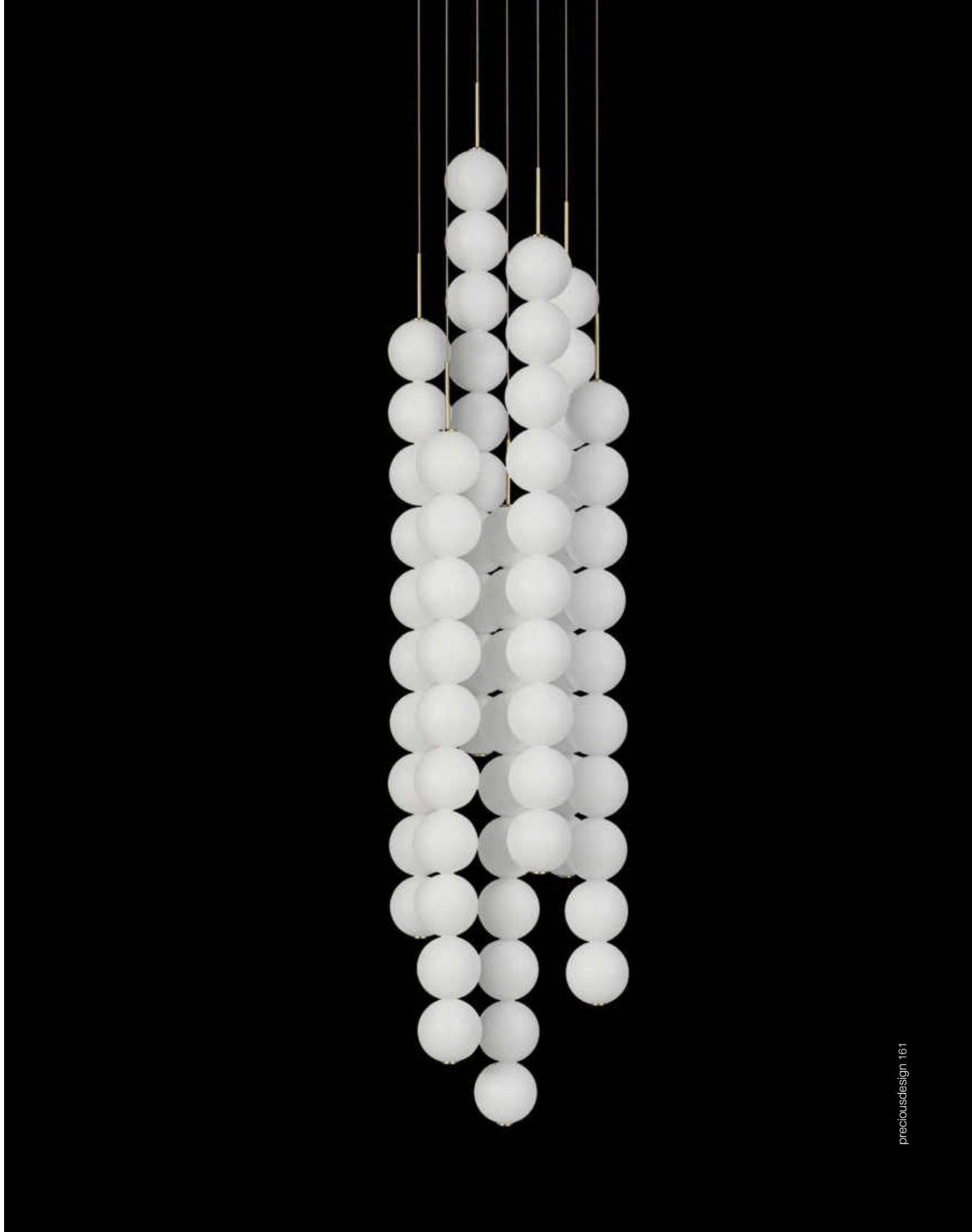





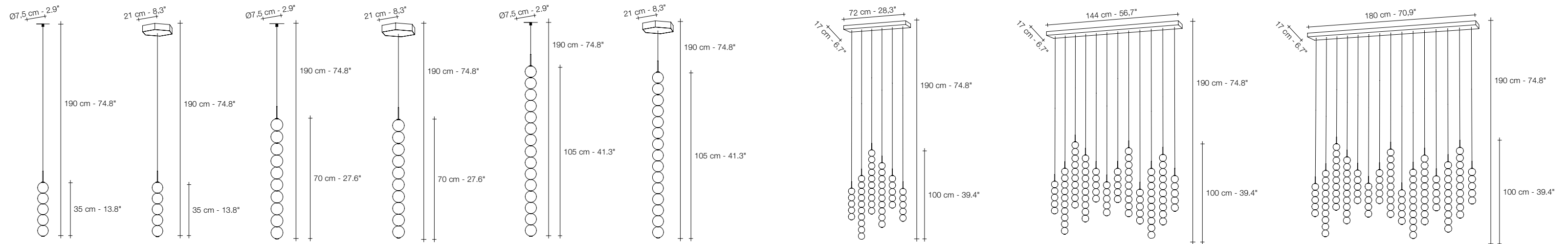

V01S 15KK 5 spheres WHITE DISC
V01S P15 5 spheres
V01S 1AKK 10 spheres WHITE DISC
V01S P1A 10 spheres
V01S 1FKK 15 spheres WHITE DISC
V01S P1F 15 spheres
V06S R2B 3x5 - 3x10 spheres
V12S R3M 6x5 - 6x10 spheres
V15S R4D 7x5 - 8x10 spheres

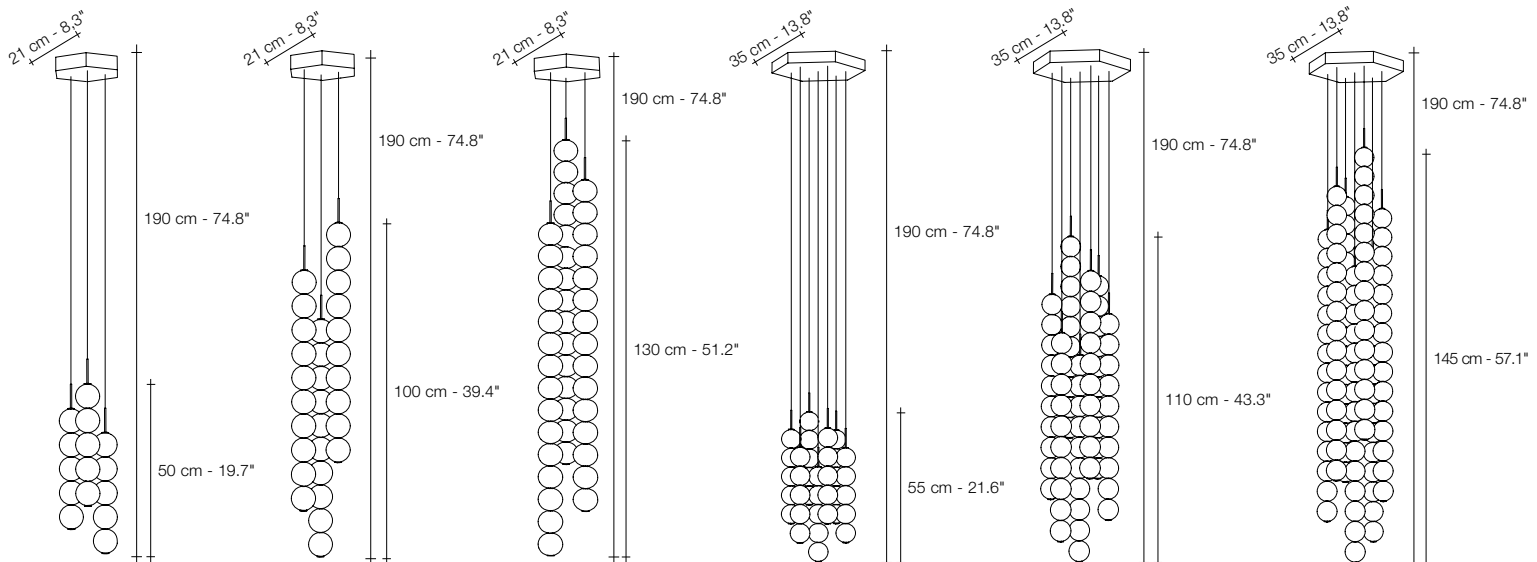

V03S P1F 3x5 spheres
V03S P1V 3x10 spheres
V03S P2B 3x15 spheres
V07S P21 7x5 spheres
V07S P32 7x10 spheres
V07S P43 7x15 spheres

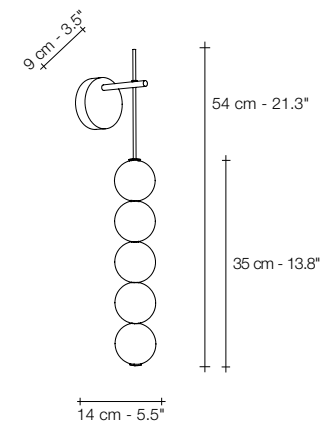

V01A 15
 5 spheres
 N/A in North America



BRASS | WHITE GLASS

	LIGHT SOURCE	V01S 15KK	V01S P15	V01S 1AKK	V01S P1A	V01S 1FKK	V01S P1F	V03S P1F	V03S P1V	V03S P2B	V07S P21	V07S P32	V07S P43
230V	Replaceable LED module 3000K	3,6W 540 lm	3,6W 540 lm	7,2W 1080 lm	7,2W 1080 lm	10,8W 1620 lm	10,8W 1620 lm	3x3,6W 1620 lm	3x7,2W 3240 lm	3x10,8W 4860 lm	7x3,6W 3780 lm	7x7,2W 7560 lm	7x10,8W 11340 lm
	Dimmable	0/1-10V 100KQ PUSH DALI	0/1-10V 100KQ PUSH DALI	0/1-10V 100KQ PUSH DALI	0/1-10V 100KQ PUSH DALI	0/1-10V 100KQ PUSH DALI	0/1-10V 100KQ PUSH DALI	0/1-10V 100KQ PUSH DALI	0/1-10V 100KQ PUSH DALI	0/1-10V 100KQ PUSH DALI	0/1-10V 100KQ PUSH DALI	0/1-10V 100KQ PUSH DALI	0/1-10V 100KQ PUSH DALI
120V	Replaceable LED module 3000K	3,6W 540 lm	3,6W 540 lm	7,2W 1080 lm	7,2W 1080 lm	10,8W 1620 lm	10,8W 1620 lm	3x3,6W 1620 lm	3x7,2W 3240 lm	3x10,8W 4860 lm	7x3,6W 3780 lm	7x7,2W 7560 lm	7x10,8W 11340 lm
	Dimmable	0-10V PWM	0-10V PWM	0-10V PWM	0-10V PWM	0-10V PWM	0-10V PWM	0-10V PWM	0-10V PWM	0-10V PWM	1-10V PWM	1-10V PWM	1-10V PWM

Different dimming options on request

	LIGHT SOURCE	V06S R2B	V12S R3M	V15S R4D	V01A 15
230V	Replaceable LED module 3000K	3x3,6W 3x7,2W 4860 lm	6x3,6W 6x7,2W 9720 lm	7x3,6W 8x7,2W 12420 lm	3,6W 540 lm
	Dimmable	0/1-10V 100KQ PUSH DALI	0/1-10V 100KQ PUSH DALI	0/1-10V 100KQ PUSH DALI	0/1-10V PUSH
120V	Replaceable LED module 3000K	3x3,6W 3x7,2W 4860 lm	6x3,6W 6x7,2W 9720 lm	7x3,6W 8x7,2W 12420 lm	-
	Dimmable	1-10V PWM	1-10V PWM	1-10V PWM	-

Different dimming options on request

In Greek mythology, Gaia is the personification of the Earth and the mother of all life. Looking to capture the mythical and natural beauty of this Earth goddess, designer Jean-François Crochet has created the Gaia pendant light. Consisting of geometric frames reminiscent of the mountains Gaia created, the pendant uses led light to push light through the “cracks” formed. The resulting light creates a magical feeling, as if the lights peeking through were alive themselves. Also available in gold, nickel, and wood finish and in custom configurations, Gaia adds a vibrancy and sacred light to any space. Design Jean-François Crochet.

Gaia, earth mother.











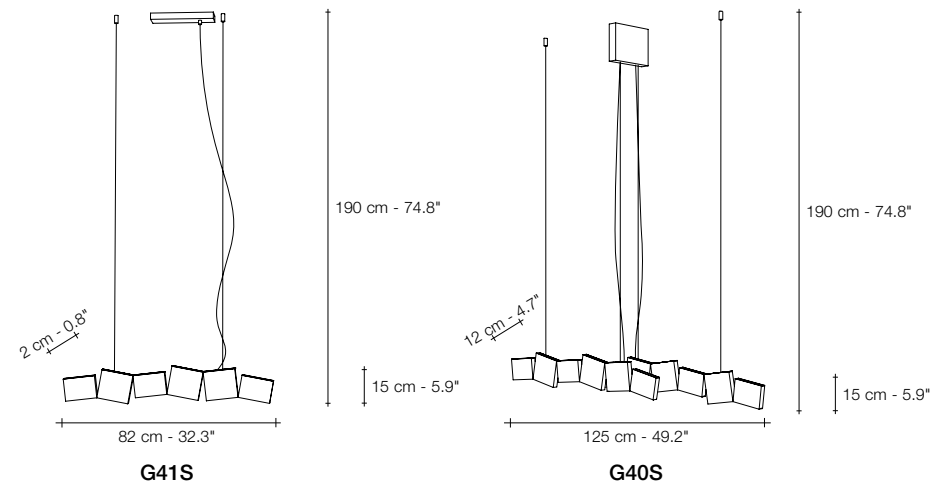

MATTE NICKEL



MATTE BLACK NICKEL



NICKEL PLATED



GOLD PLATED

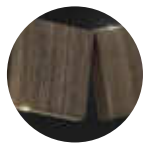

MATT WALNUT

		G41S		G40S	
230V	⊙	Replaceable LED module	12x1,5W	24x1,5W	
		3000K	2088 lm	4176 lm	
		2700K	1968 lm	3936 lm	
		Dimmable	1-10V PUSH/DALI	0/1-10V PUSH/DALI	
120V	⊙	Replaceable LED module	12x1.5W	24x1.5W	
		3000K	2088 lm	4176 lm	
		2700K	1968 lm	3936 lm	
		Dimmable	1-10V PUSH	0/1-10V PUSH/DALI	

Gaia available with integrated LED 3000K or 2700K. Different dimming options on request.



I Lucci Argentati, school of light.

I Lucci Argentati draws from nature to create a whimsical, yet modern light. Recalling a school of fish darting through freshwater, it creates a mesmerizing luminescence. Sets of sleek elements combine to form a stunning pendant with thin incisions along the bottom, creating an understated, tranquil beauty. Thanks to its modular system, I Lucci Argentati is customizable and can be combined in many different configurations: from small to extra large, and finished either in brushed nickel, brushed gold, or white. Design Dodo Arslan.













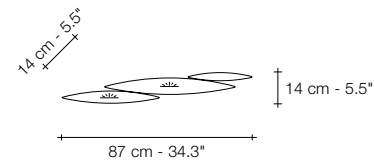
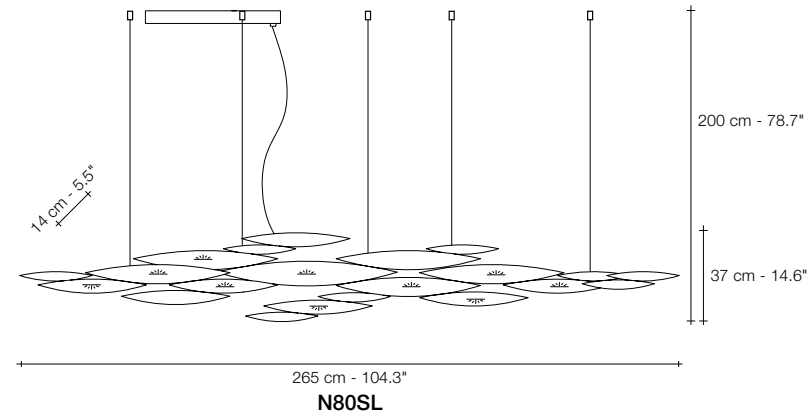
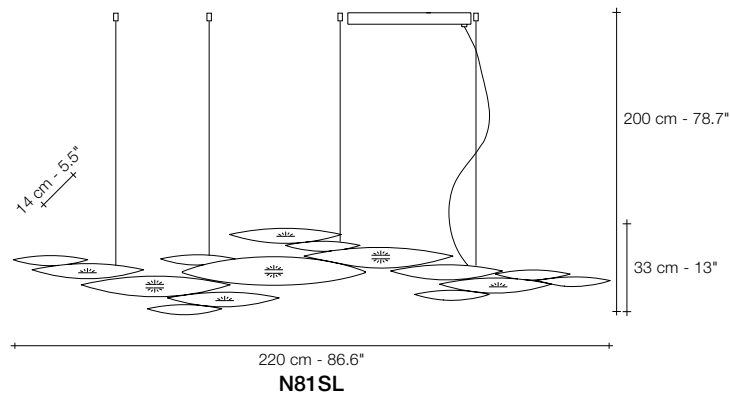
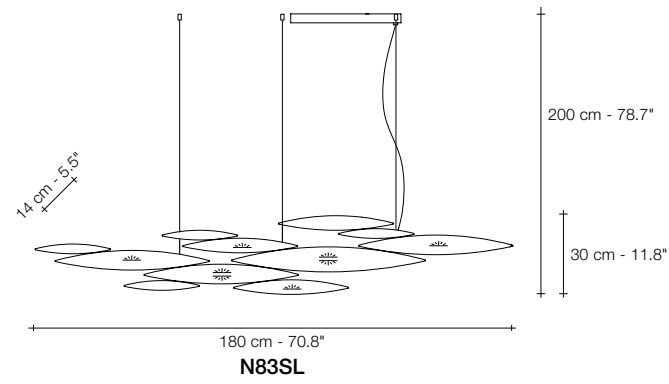
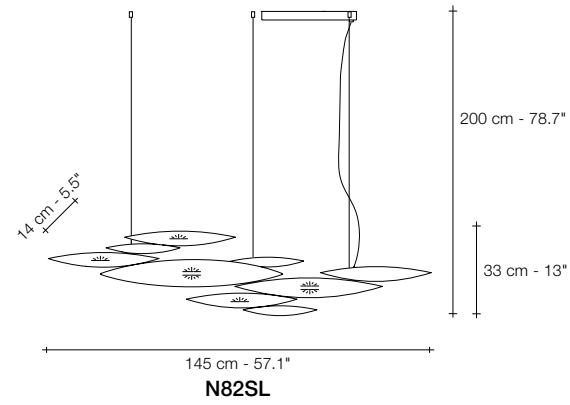

BRUSHED
NICKEL PLATED

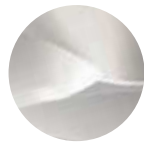

WHITE
POLISHED



BRUSHED
GOLD PLATED

	N82SL	N83SL	N81SL	N80SL	N85ALB	
230V	LIGHT SOURCE	N82SL	N83SL	N81SL	N80SL	N85ALB
	Replaceable LED module	7x4,5W	8x4,5W	10x4,5W	10x4,5W	2x4,5W
	CRI 90 3000K	4632 lm	5294 lm	6617 lm	6617 lm	1323 lm
	2700K	4200 lm	4800 lm	6000 lm	6000 lm	1200 lm
Dimmable	0-10V PWM PUSH/DALI	0-10V PWM PUSH/DALI	0-10V PWM PUSH/DALI	0-10V PWM PUSH/DALI	0/1-10V PUSH/DALI	
120V	LIGHT SOURCE	N82SL	N83SL	N81SL	N80SL	N85ALB
	Replaceable LED module	7x4,5W	8x4,5W	10x4,5W	10x4,5W	2x4,5W
	CRI 90 3000K	4632 lm	5294 lm	6617 lm	6617 lm	1323 lm
	2700K	4200 lm	4800 lm	6000 lm	6000 lm	1200 lm
Dimmable	TRIAC	1-10V PWM 10-100kΩ	1-10V PWM 10-100kΩ	1-10V PWM 10-100kΩ	no	

I Lucci Argentati available with integrated LED 3000K or 2700K. Different dimming options on request.



Atlantis, a precious wave.

Seemingly alive, Atlantis' shimmering light creates a vibrant source of energy. Its mesmerizing, organic effect is created by hundreds of illuminated lengths of draped chains. Like water in the ocean, Atlantis's chains appear liquid, cascading over its gloss bands and falling down towards the abyss before turning back into itself. Atlantis is composed of almost three miles of chain, meticulously hand-crafted by master Italian artisans. Design Barlas Baylar.























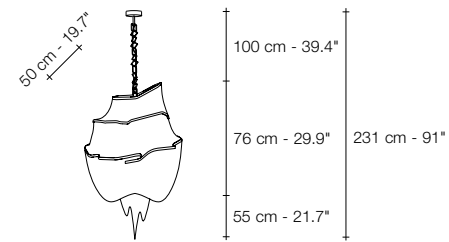

50 cm - 19.7"

A13S

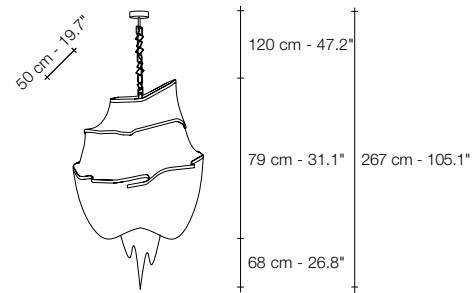

65 cm - 25.6"

A14S

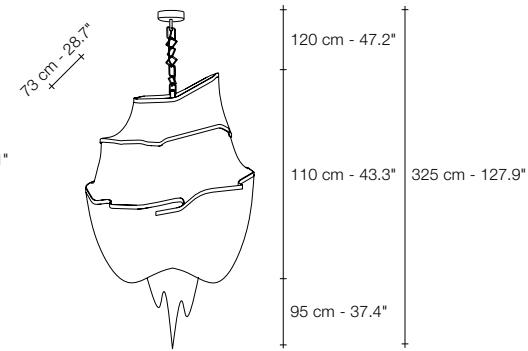

90 cm - 35.4"

A15S

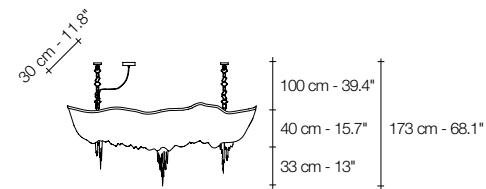

150 cm - 59.1"

A18S

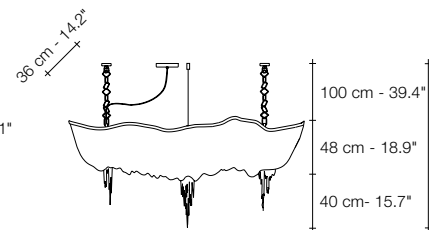

200 cm - 78.7"

A17S

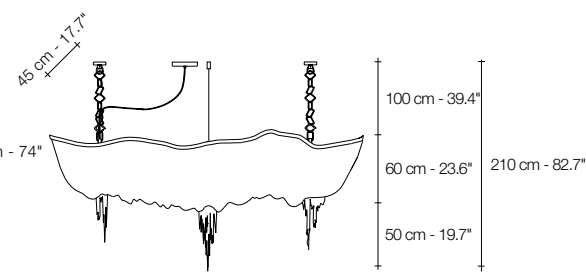

250 cm - 98.4"

A16S

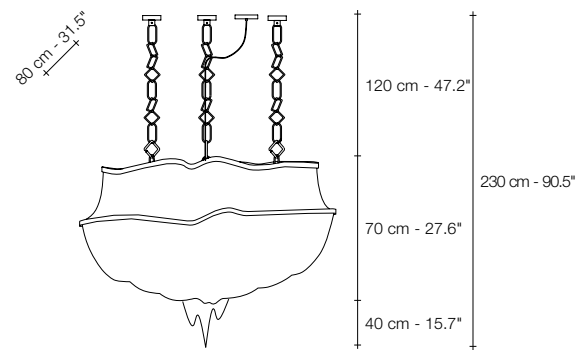

110 cm - 43.3"

J01S

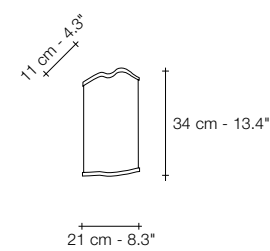

21 cm - 8.3"

J04A

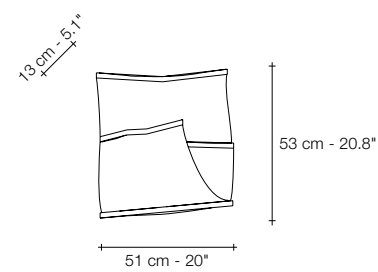

51 cm - 20"

J03A



NICKEL PLATED

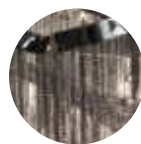

BLACK NICKEL PLATED



BRUSHED BRONZE



GOLD PLATED



CHAMPAGNE PLATED



BRUSHED CHAMPAGNE PLATED

LIGHT SOURCE		A13S	A14S	A15S	A18S	A17S	A16S	J01S	J04A	J03A
230V	E14 LED	6x6W	8x6W	8x6W	8x6W	10x6W	10x6W	8x6W	2x6W	4x6W
	Dimmable	✓	✓	✓	✓	✓	✓	✓	✓	✓
120V	E12 LED	6x5.5W	8x5.5W	8x5.5W	8x5.5W	10x5.5W	10x5.5W	8x5.5W	2x5.5W	4x5.5W
	Dimmable	✓	✓	✓	✓	✓	✓	✓	✓	✓



Epoque, cyclical light.

Epoque is a light sculpture designed to study chiaroscuro and volumes. The result is a modern expression of these Renaissance-era techniques in a stunning chandelier. Composed of curved, organic lines, Epoque's frame is made of flexible and durable brass metal, suspended by metal chains. Two bands of metal, a central elongated section, and an external band of wide arcs allow the light to envelop a room in reflections of soft light. Epoque has attracted attention from those in the design community with discerning tastes. Epoque is available in nickel, black nickel, bronze, and gold finish. Design Stefano Papi & Saviz Yaghmai.





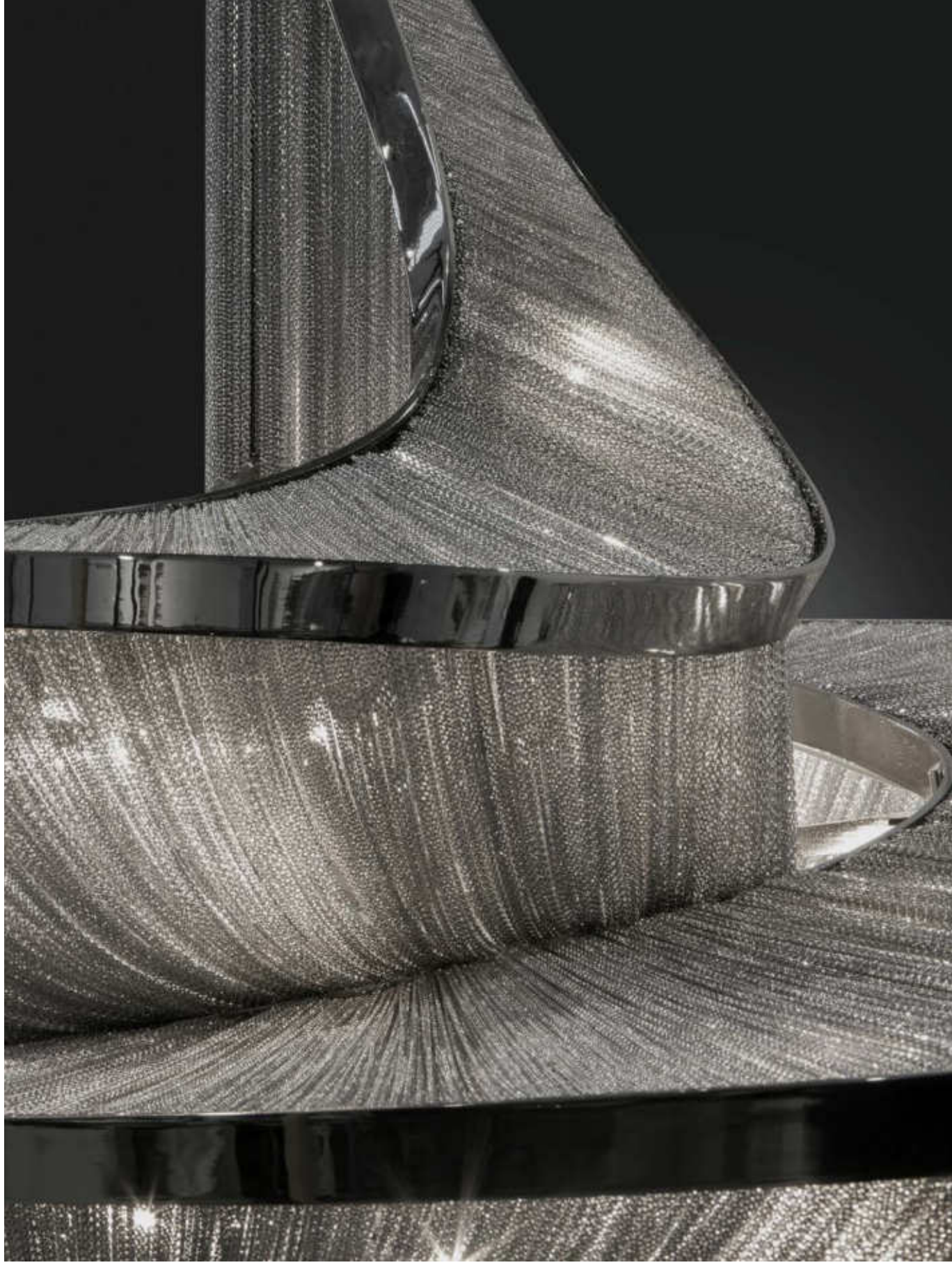



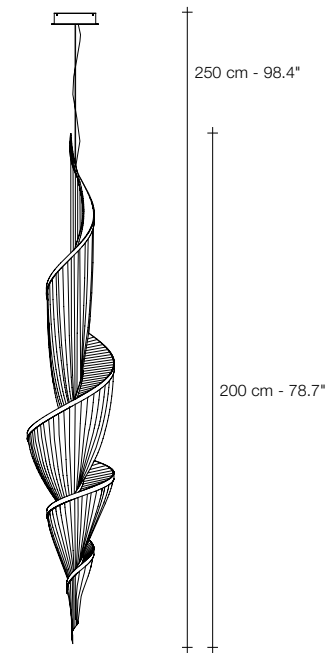

Ø35 cm - 13.8"

G91S

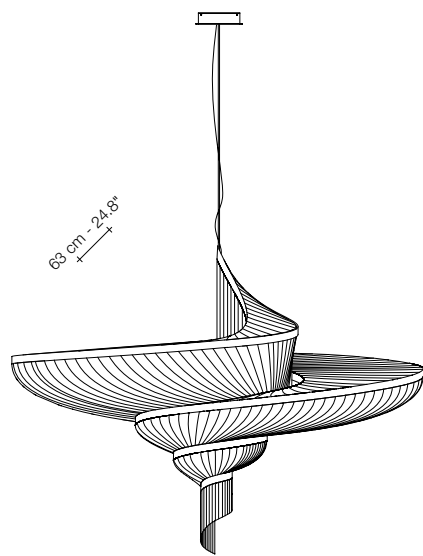

136 cm - 53.5"

G90S



NICKEL
PLATED

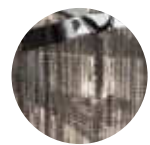

BLACK NICKEL
PLATED



BRUSHED
BRONZE



GOLD
PLATED

		G91S	G90S
230V	Replaceable LED module	12x2,1W	20x2,1W
	3000K 2700K	2844 lm 2676 lm	4740 lm 4460 lm
	Dimmable	0/1-10V PUSH/DALI	PUSH DALI
120V	Replaceable LED module	12x2,1W	20x2,1W
	3000K 2700K	2844 lm 2676 lm	4740 lm 4460 lm
	Dimmable	0/1-10V PUSH/DALI	1-10V PWM 10-100kΩ

Epoque available with integrated LED 3000K or 2700K. Different dimming options on request.



Volver, breath of new light.

At Terzani, we are fortunate to work with some of the brightest young stars in Italian design. For Volver, designer Diego Bassetti and architect Andrea Panzeri of Studio 14, protégés of Bruno Rainaldi, applied their multidisciplinary approach to create Terzani's first led suspension light. This geometric design combines thin chains with the latest in led technology to create a light that is both elegant and modern. A breath of new light, Volver melds technology and art to achieve a new level of luxury. Available in a circular variation. Design Studio 14.







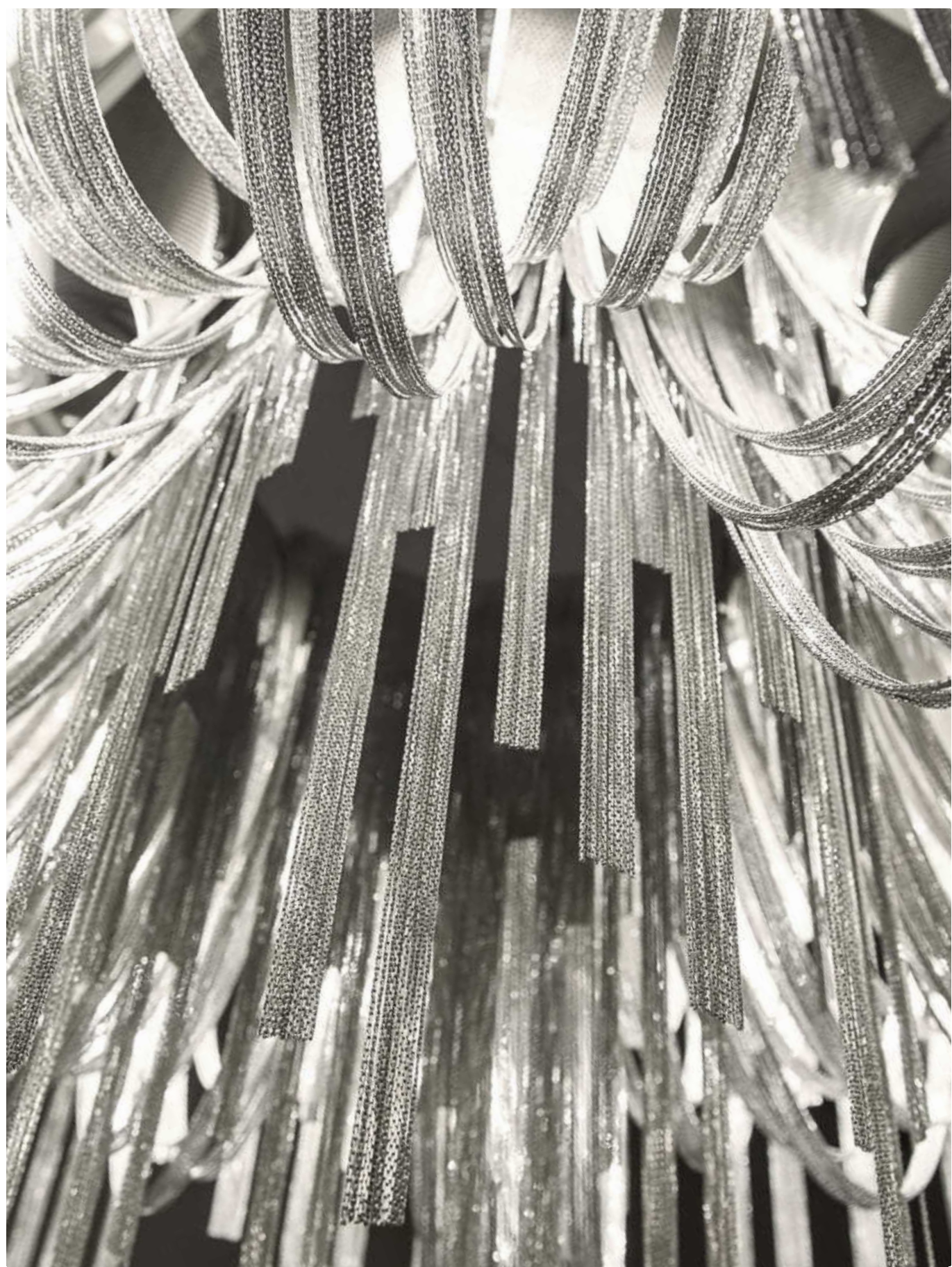

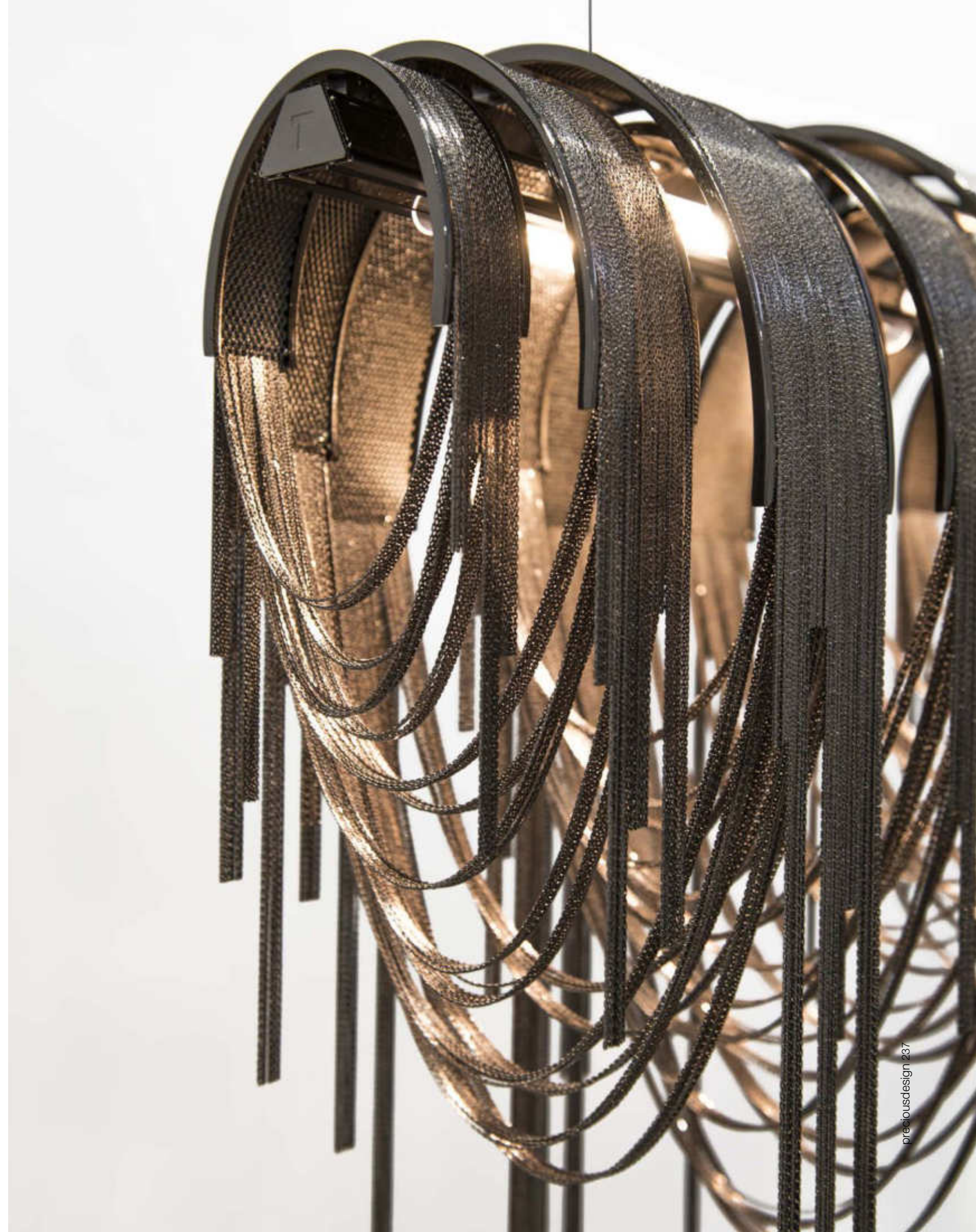

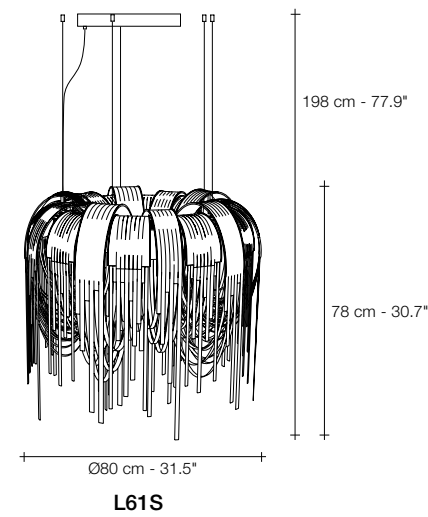
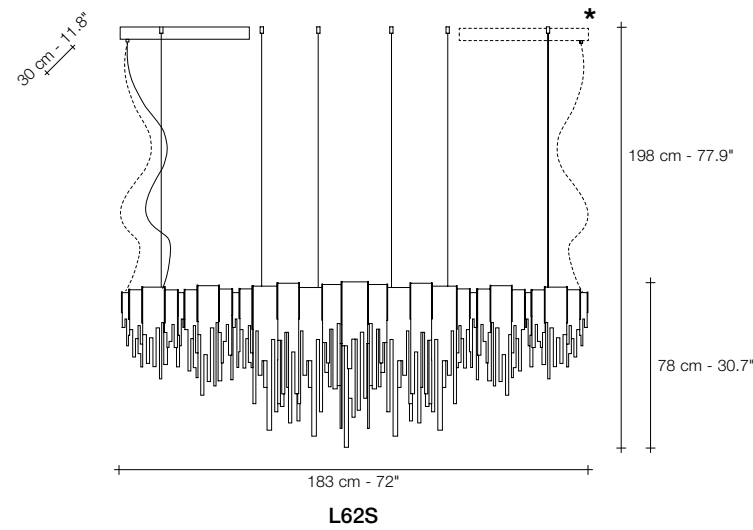
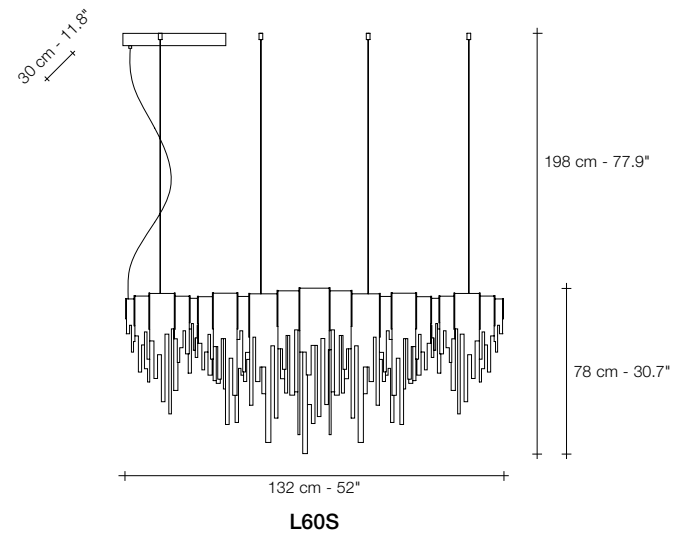
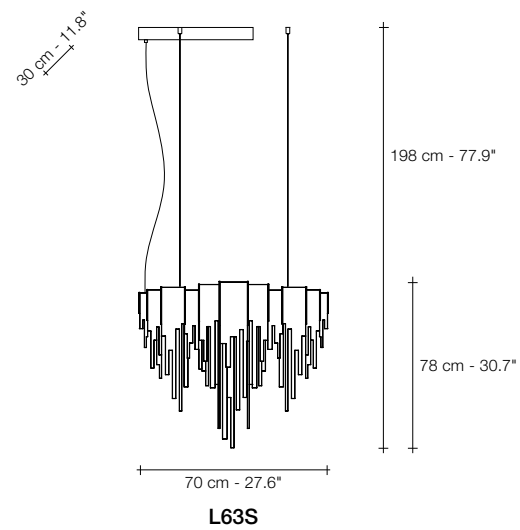

NICKEL PLATED



BLACK NICKEL PLATED



GOLD PLATED



BRUSHED BRONZE

	L63S	L60S	L62S	L61S
230V	LIGHT SOURCE			
	Replaceable LED module			
	CRI 90 3000K 2700K			
	Dimmable			
120V	L63S			
	Replaceable LED module			
	CRI 90 3000K 2700K			
	Dimmable			

Volover available with integrated LED 3000K or 2700K. Different dimming options on request.
 * Only 120V version has two canopies.



Stream, iridescent light.

Another stunning design from Christian Lava, Stream is an impressive presence in any room. Like Christian's other work for Terzani, Etoile, Stream's design exploits the physical characteristics of the materials used to envelop a room in unique, immersive light. Here, over seven kilometers of metal chain appear to flow down from the undulating, plated frame. These cascading tiers project streaking, yet tranquil, shadows throughout the room. Design Christian Lava.













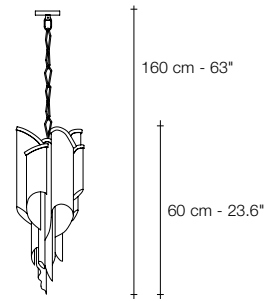

Ø30 cm - 11.8"

J54S

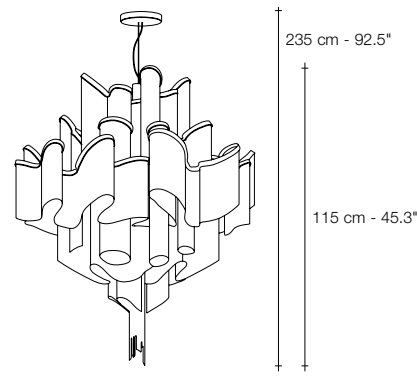

Ø80 cm - 31.5"

J51S

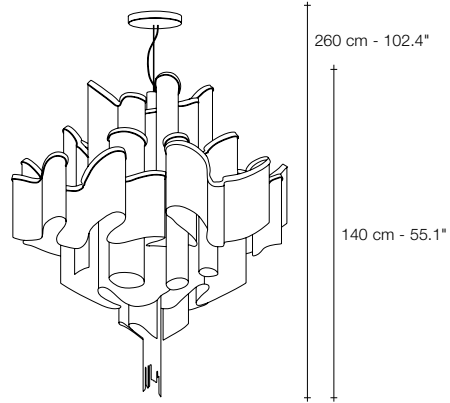

Ø110 cm - 43.3"

J50S

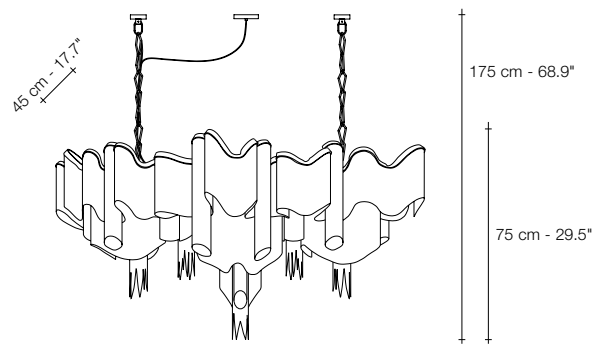

140 cm - 55.1"

J52S

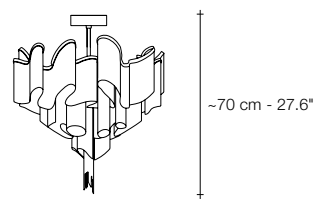

Ø60 cm - 23.6"

J70L

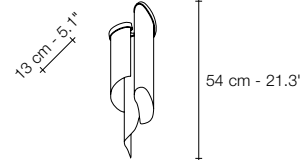

20 cm - 7.9"

J60A

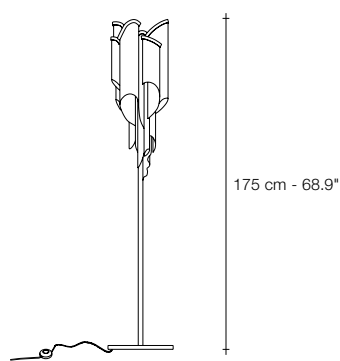

Ø36 cm - 14.2"

J65P



NICKEL PLATED

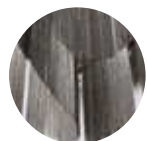

BLACK NICKEL PLATED



GOLD PLATED

LIGHT SOURCE		J51S	J50S	LIGHT SOURCE			J54S	J52S	J70L	LIGHT SOURCE		J60A	J65P		
230V		E14 LED GU10 LED	18x4W 5W	20x4W 5W	230V		G9 LED GU10 LED	4x3,5W 5W	12x3,5W 3x5W	8x3,5W 5W	230V		E14 LED	2x6W	6x6W
		Dimmable	✓	✓			Dimmable	✓	✓	✓			Dimmable	✓	✓
120V		E12 LED GU10 LED	18x4W 6W	20x4W 6W	120V		G9 LED GU10 LED	4x4W 6W	12x4W 3x6W	8x4W 6W	120V		E12 LED	2x5.5W	6x5.5W
		Dimmable	✓	✓			Dimmable	✓	✓	✓			Dimmable	✓	✓



Soscik, classic form, modern look.

Terzani continues to reinvent the classics with Soscik, which combines traditional artisan techniques with cutting-edge technology to give the traditional chandelier a modern update. Created by interlacing metal chain over the frame, Soscik creates a dramatic and romantic effect while still complementing today's modern luxury. Available as a chandelier or a ceiling lamp, Soscik proves that modern design does not have to sacrifice luxury. Design Nicolas Terzani.







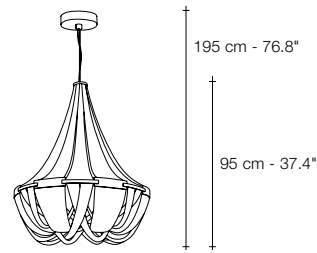

Ø72 cm - 28.4"

G55S

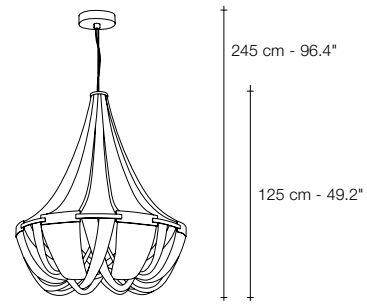

Ø100 cm - 39.4"

G56S

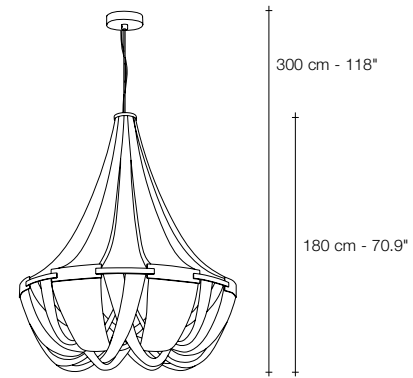

Ø145 cm - 57.1"

G57S

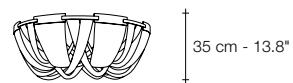

Ø72 cm - 28.4"

G60L



Ø100 cm - 39.4"

G61L

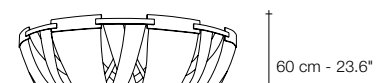

Ø145 cm - 57.1"

G62L



NICKEL PLATED |
BRUSHED
NICKEL PLATED

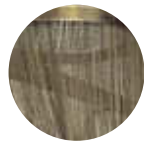

BRUSHED
BRONZE



GOLD PLATED |
BRUSHED
GOLD PLATED



CHAMPAGNE PLATED |
BRUSHED CHAMPAGNE
PLATED

LIGHT SOURCE		G55S	G56S	G57S	G60L	G61L	G62L
230V	G9 LED	8x3,5W	12x3,5W	14x3,5W	8x3,5W	10x3,5W	12x3,5W
	Dimmable	✓	✓	✓	✓	✓	✓
120V	G9 LED	8x4W	12x4W	14x4W	8x4W	10x4W	12x4W
	Dimmable	✓	✓	✓	✓	✓	✓



Doodle, freehand design.

We no longer march in a straight line. Our lives are dynamic, intertwining collections of relationships, experiences, and journeys. Reflecting the fluidity of our generation, designer Simone Micheli has created a new, contemporary light for Terzani, Doodle. Like us, each Doodle is unique; each pendant is handcrafted by artisans to resemble a randomized path. And, to give us control over the journey we want to take, each led bulb can be placed anywhere on the light, not only reflecting the choices we make in life, but also giving Doodle special flexibility. Available in nickel, black nickel, gold, and copper plated finishes. Design Simone Micheli.

















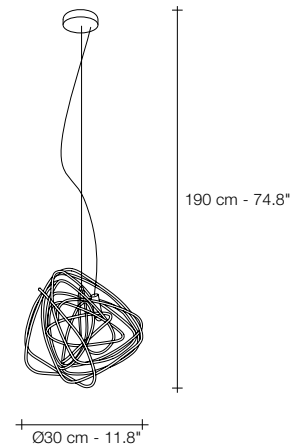

J80S

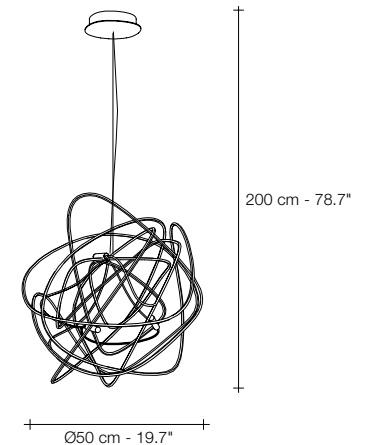

J93S

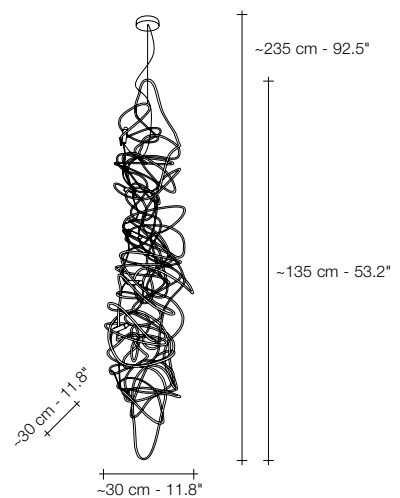

J87S

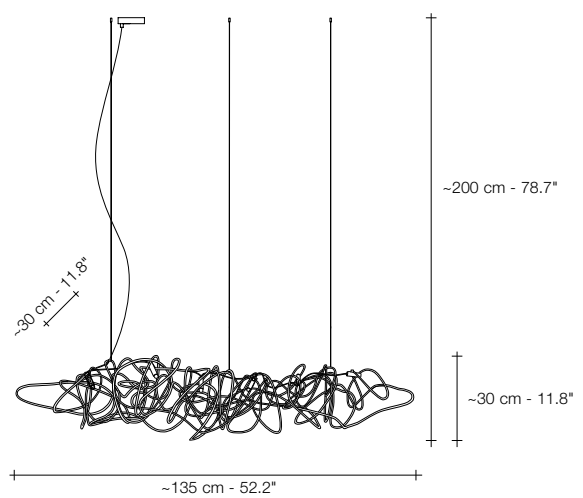

J81S

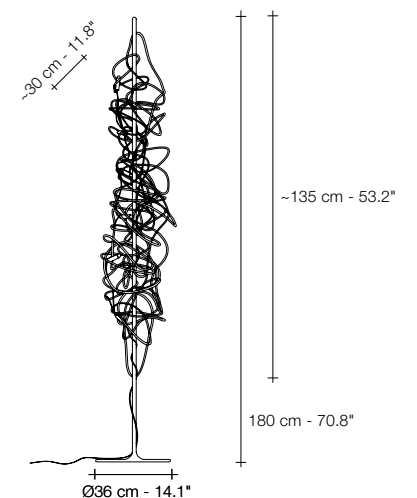

J86P

N/A in North America

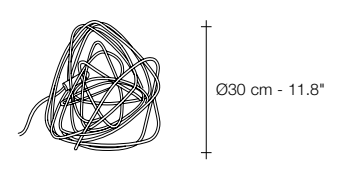

J84B

N/A in North America

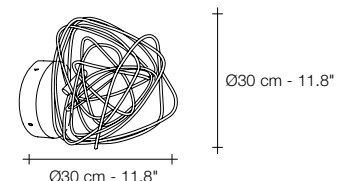

J82A



	LIGHT SOURCE	J80S	J93S	J87S	J81S	J86P	J84B	J82A
230V	G4 LED	2W	5x2W 2W	6x2W 2W	6x2W 2W	6x1,2W 1,2W	2W	2W
	Dimmable	0/1-10V 100KQ PUSH DALI	IGBT/DALI 1-10V PWM	IGBT/DALI 1-10V PWM	IGBT/DALI 1-10V PWM	no	no	0/1-10V 100KQ PUSH DALI
120V	G4 LED	2W	5x2W	6x2W	6x2W	-	-	2W
	Dimmable	no	ELV	ELV	ELV	-	-	ELV

Different dimming options on request



Core, eruption of light.

Core, designed by Christian Lava, is reminiscent of the natural energy at the heart of our world. Like bright lava seeping through the earth's crust, vibrant spheres of faceted glass break through the iron surface of this pendant. Forcing light to pass through this metal structure results in a powerful, vibrant exchange of forces; light and shadow erupt across the room, and the led light pours through, as the light itself emits an organic radiance. Available in nickel, black nickel, and gold plated finishes. Design Christian Lava.









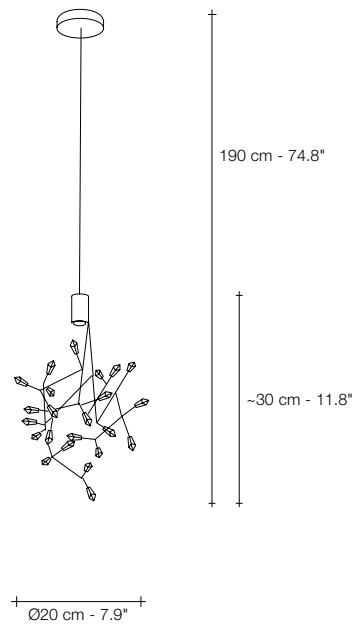

P22S

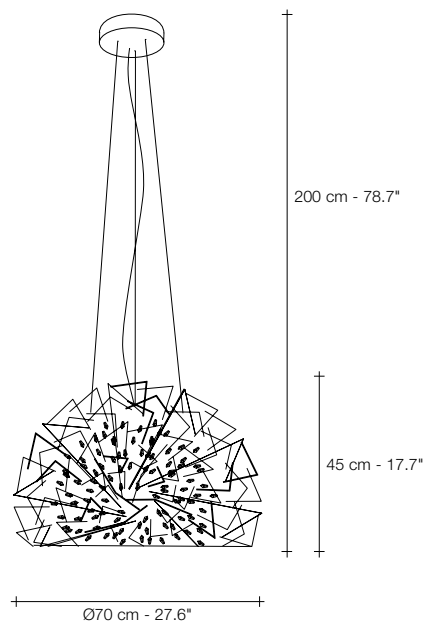

P21S

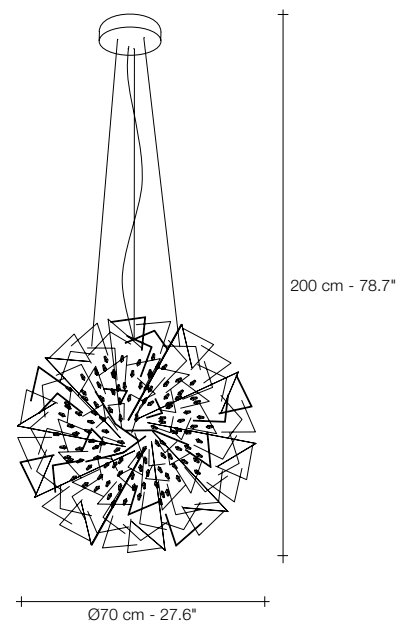

P20S



NICKEL PLATED | CLEAR GLASS



BLACK NICKEL PLATED | CLEAR GLASS

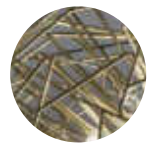

GOLD PLATED | CLEAR GLASS

VOLTAGE	LIGHT SOURCE		P22S	P21S	P20S
	230V	Replaceable LED module 3000K 2700K	2,1W 237 lm 223 lm	18W 1640 lm 1570 lm	18W 1640 lm 1570 lm
	Dimmable	no	1-10V PUSH/DALI	1-10V PUSH/DALI	
120V	Replaceable LED module 3000K 2700K	2,1W 237 lm 223 lm	18W 1640 lm 1570 lm	18W 1640 lm 1570 lm	
	Dimmable	no	1-10V PUSH	1-10V PUSH	

Core available with integrated LED 3000K or 2700K. Different dimming options on request.



Calle, perennial elegance.

At Terzani, we spend countless days searching the globe for talented new designers, but sometimes they find us. Such is the case with the young designers Luca Martorano and Mattia Albicini (Draw), who approached us with the design for Calle, a fantastic new light we instantly fell in love with. It showcases our skill at crafting crystal, taking the material to an exciting, modern place. Luca and Mattia worked with our craftsmen to create a slender inverted flute of crystal that, like the calla lily it mimics, can be grouped into stunning bouquets of light. Design Draw.









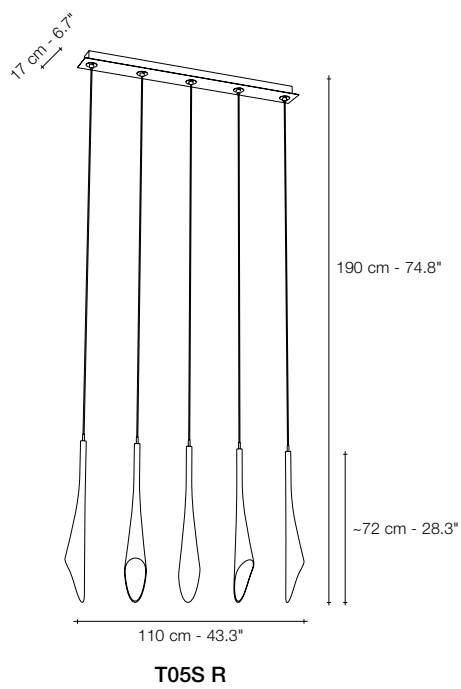
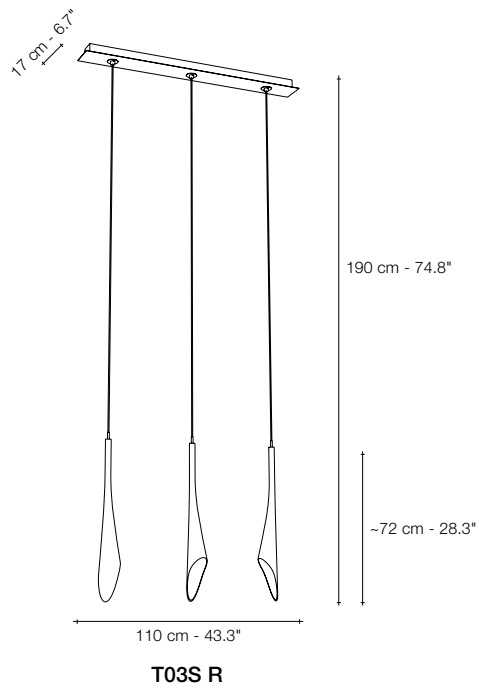
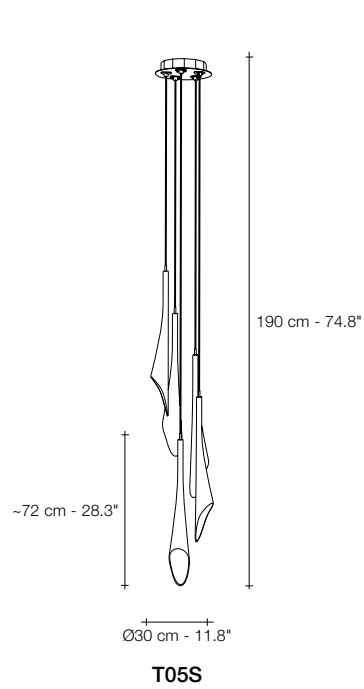
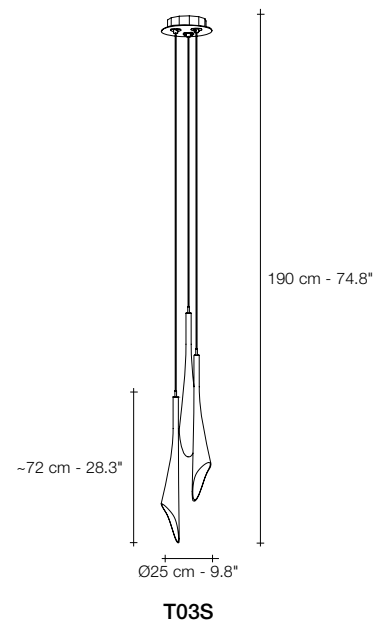
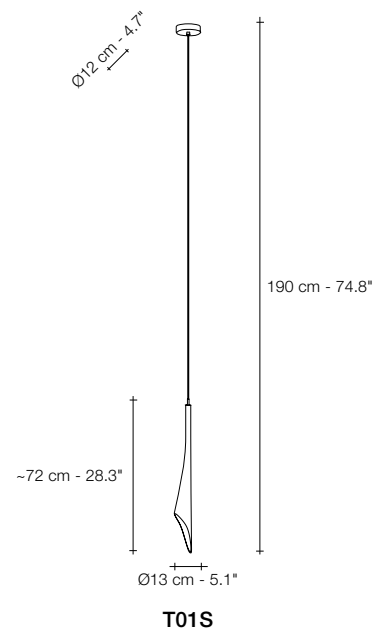
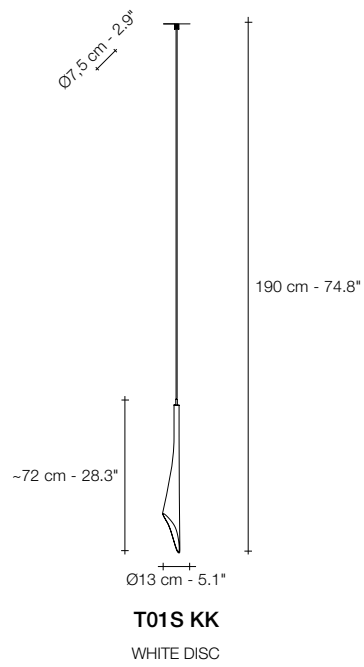

WHITE |
CLEAR CRYSTAL

LIGHT SOURCE OPTIONS		T01S KK	T01S	T01S	T03S	T03S R	T05S	T05S R
230V	G4 LED	2W	2W	3W	3x2W	3x2W	5x2W	5x2W
	G4 HALOGEN	20W	20W	20W	3x20W	3x20W	5x20W	5x20W
	Dimmable	0/1-10V 100KΩ PUSH DALI	IGBT TRIAC	DALI	IGBT DALI	IGBT DALI	IGBT 1-10V PWM DALI	IGBT 1-10V PWM DALI
120V	G4 LED	2W	2W	-	3x2W	3x2W	5x2W	5x2W
	G4 XENON	20W	20W	-	3x20W	3x20W	5x20W	5x20W
	Dimmable	ELV	ELV	-	ELV	ELV	ELV	ELV

Different dimming options on request



Angel falls, cast down to earth.

For his work with Terzani, Nigel Coates, well known for his unorthodox approach to design, has created an engaging, unique light. Customizable groups of handmade crystal “angels” are illuminated by halogen or led lamps. What caused these angels to fall from the heavens? It’s up to the viewers to decide. Either way, Angel Falls is sure to garner attention and generate conversation in any setting. Design Nigel Coates.





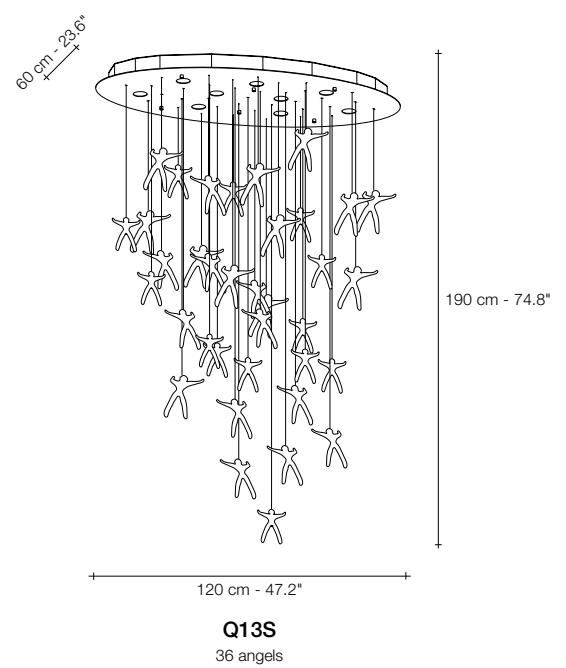
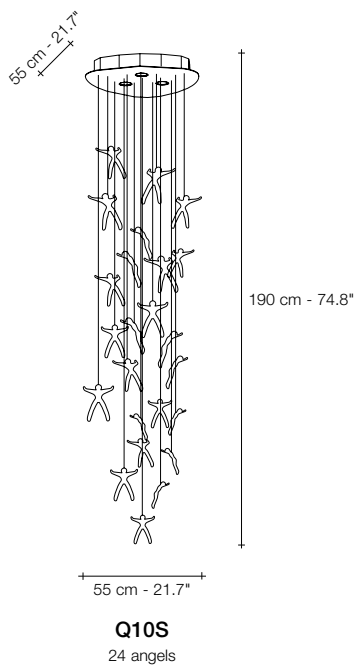
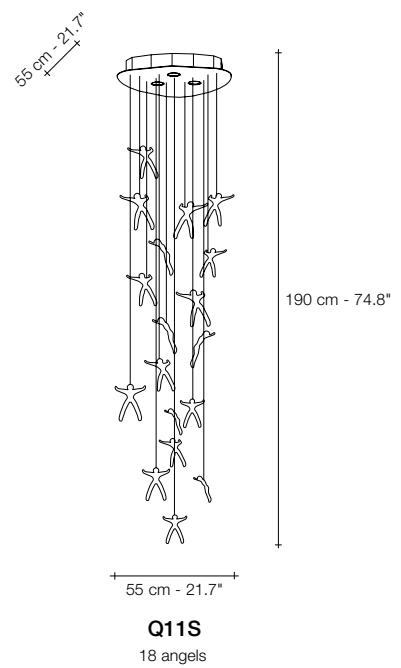
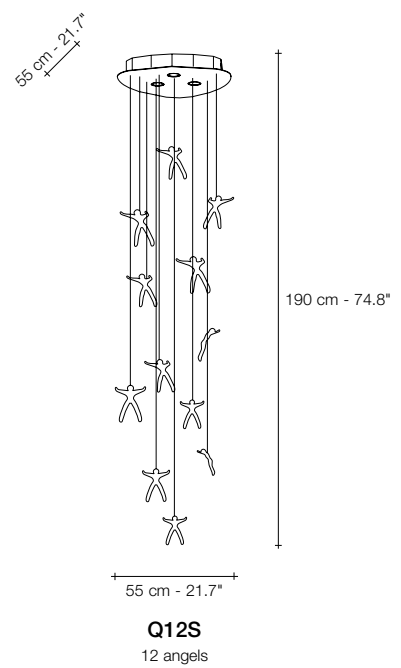
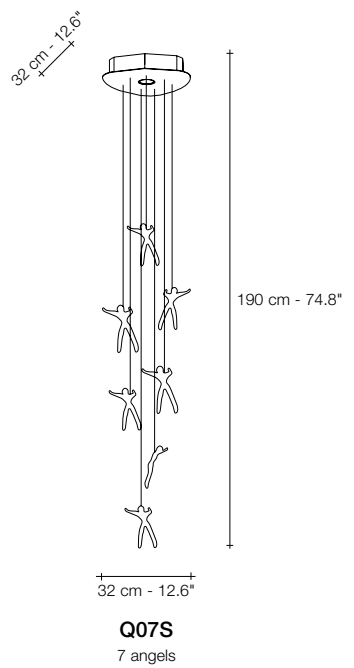

CRYSTAL

LIGHT SOURCE		Q07S	Q12S	Q11S	Q10S	Q13S
230V	GU10 LED	5W	3x5W	3x5W	3x5W	9x4W
	Dimmable	✓	✓	✓	✓	✓
120V	GU10 LED	7W	3x7W	3x7W	3x7W	9x6W
	Dimmable	✓	✓	✓	✓	✓



Oscar, a tribute.

The great Brazilian architect Oscar Niemeyer once said about his work: "It's not the right angle that attracts me, nor the straight line: stiff, inflexible, created by men. What really attracts me is the free, sensual curve. The curve I see on the sinuous course of our rivers, on the clouds in the sky, on your favorite woman's body. The universe is entirely made of curves." Inspired to pay tribute to one of the founders of modern architecture, designer Dodo Arslan has created a series of lights named "Oscar", which pay homage through their adoption of Niemeyer's signature sensuous curves. Oscar table lamp consists of a glass orb delicately held by curved brass. Available in nickel, brass, black, white, gold plated, and rose gold finish. Design Dodo Arslan.

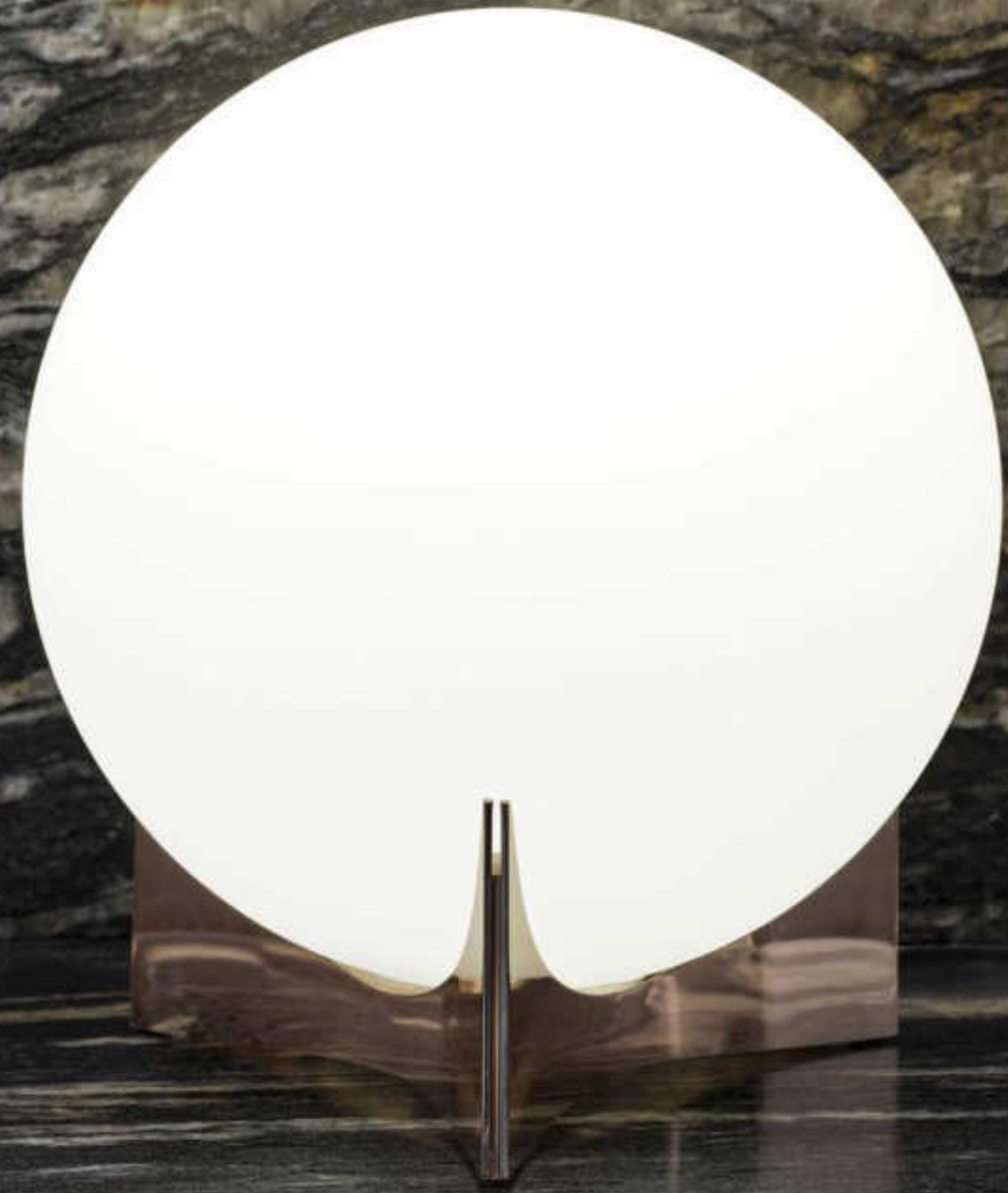







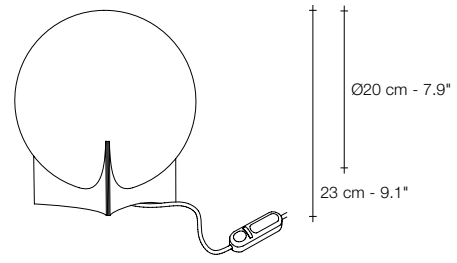

C02B

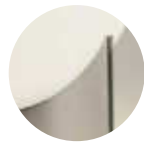

NICKEL PLATED | SATIN WHITE GLASS



SATIN BRASS | SATIN WHITE GLASS



BLACK | SATIN WHITE GLASS

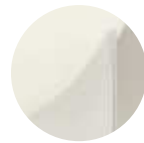

WHITE | SATIN WHITE GLASS



GOLD PLATED | SATIN WHITE GLASS



ROSE GOLD PLATED | SATIN WHITE GLASS

LIGHT SOURCE

C02B

230V



E14 LED

7W

Dimmable



120V



E12 LED

7W

Dimmable



Moiré, movement with pattern.

A French term derived from silk with a rippled or “watered” appearance, moiré is an optical effect that results in the illusion of waves or the movement of water. This effect is achieved by having an opaque, ruled pattern overlaid on another. Designer Christian Lava’s studies of this effect have led to his latest design, aptly titled Moiré. Using overlapping grids of metal, this led pendant light dynamically changes shape, following the viewer’s gaze, practically coming to life with a vibrating energy. Moiré is a mesmerizing addition to any room. Available in gold plated and nickel finish. Design Christian Lava.









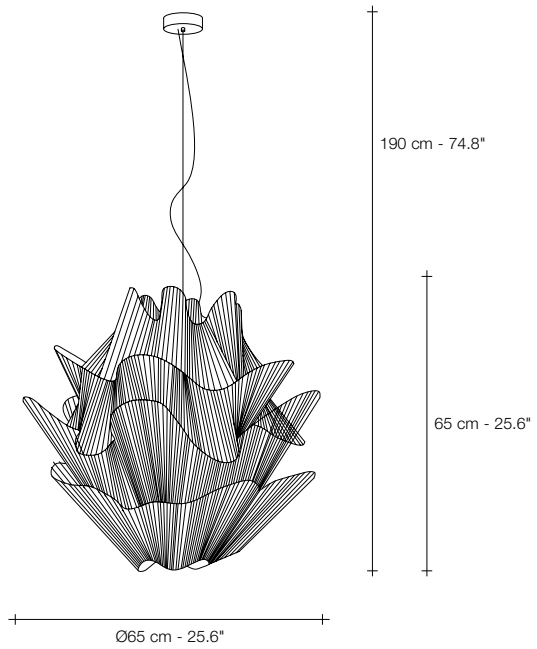

M10S



NICKEL
PLATED



GOLD
PLATED

LIGHT SOURCE		M10S
230V	Replaceable LED module 3000K	15W 1952 lm
	Dimmable	1-10V PUSH/DALI
120V	Replaceable LED module 3000K	15W 1952 lm
	Dimmable	1-10V PUSH

Different dimming options on request.



Iceberg, pure light.

Inspired by the natural beauty of ice crystals, this new suspension light creates a spectacular, luminous piece through the use of over 4086 plexyglass tubes. Similar to light refracting through water, the illumination created by Iceberg is both brilliant and natural. Meticulously handcrafted, each light is a unique sculpture: sparkling, multifaceted, and powerful. Design Dodo Arslan.



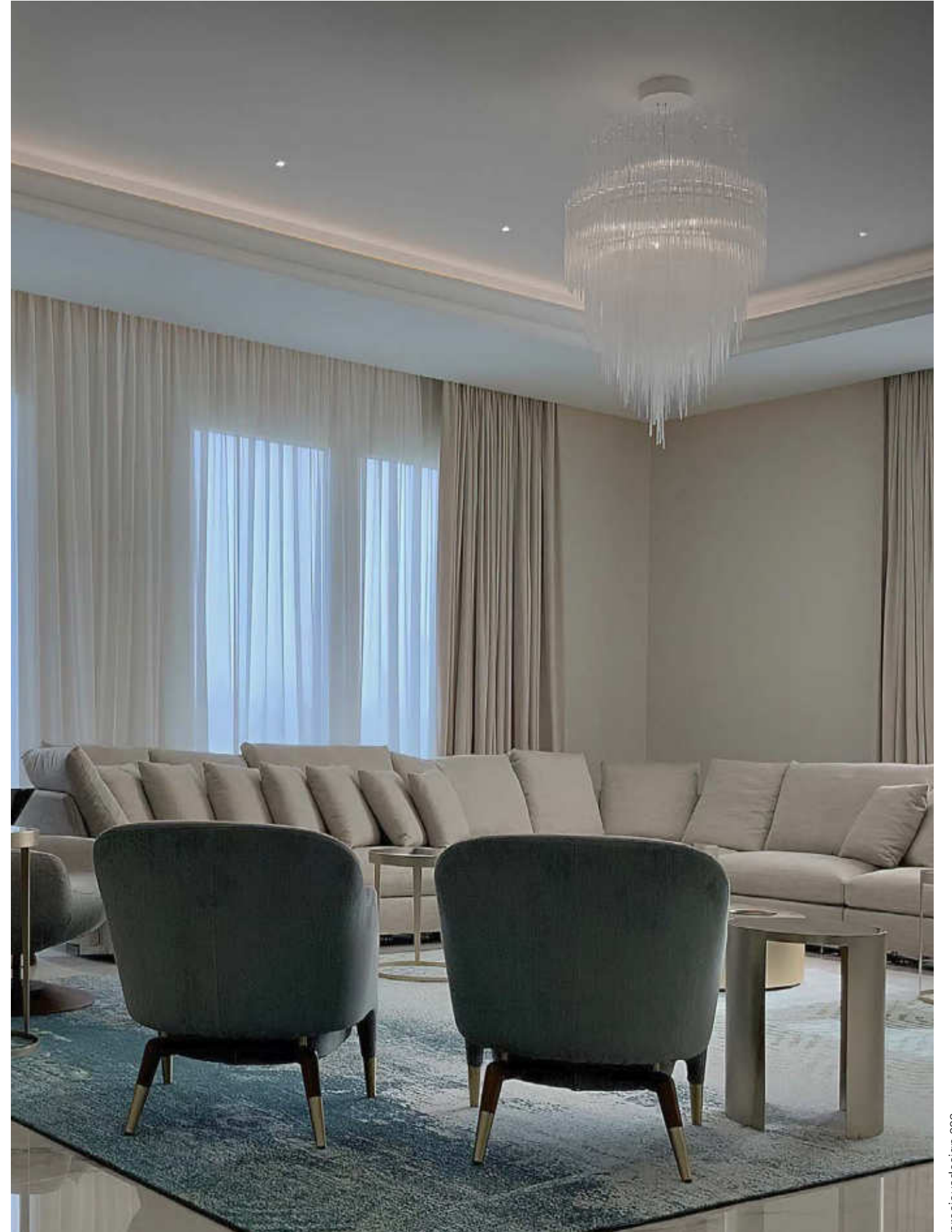

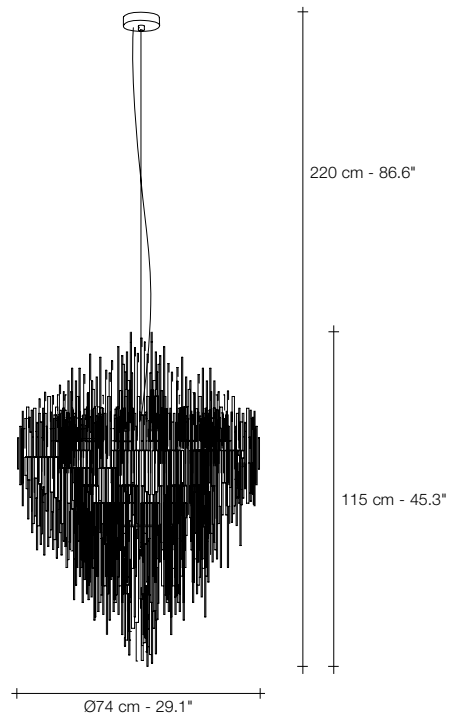



P60S



CLEAR
PLEXIGLASS

LIGHT SOURCE **P60S**

230V   **E14 LED** | **6x6W**
E27 LED | **8W**
Dimmable | ✓

120V   **E12 LED** | **6x5.5W**
E26 LED | **8W**
Dimmable | ✓



Frame, nature's imprint.

Capturing a moment in time, Frame features a metal coral leaf enclosed inside borosilicate glass, preserving a delicate imprint of nature. Hidden inside is a single bulb that glows from within. This creates a stirring light that projects a dynamic shadow due to the permeable coral. Frame is available in white, gold plated, or silver plated. Design Terzani Lab.





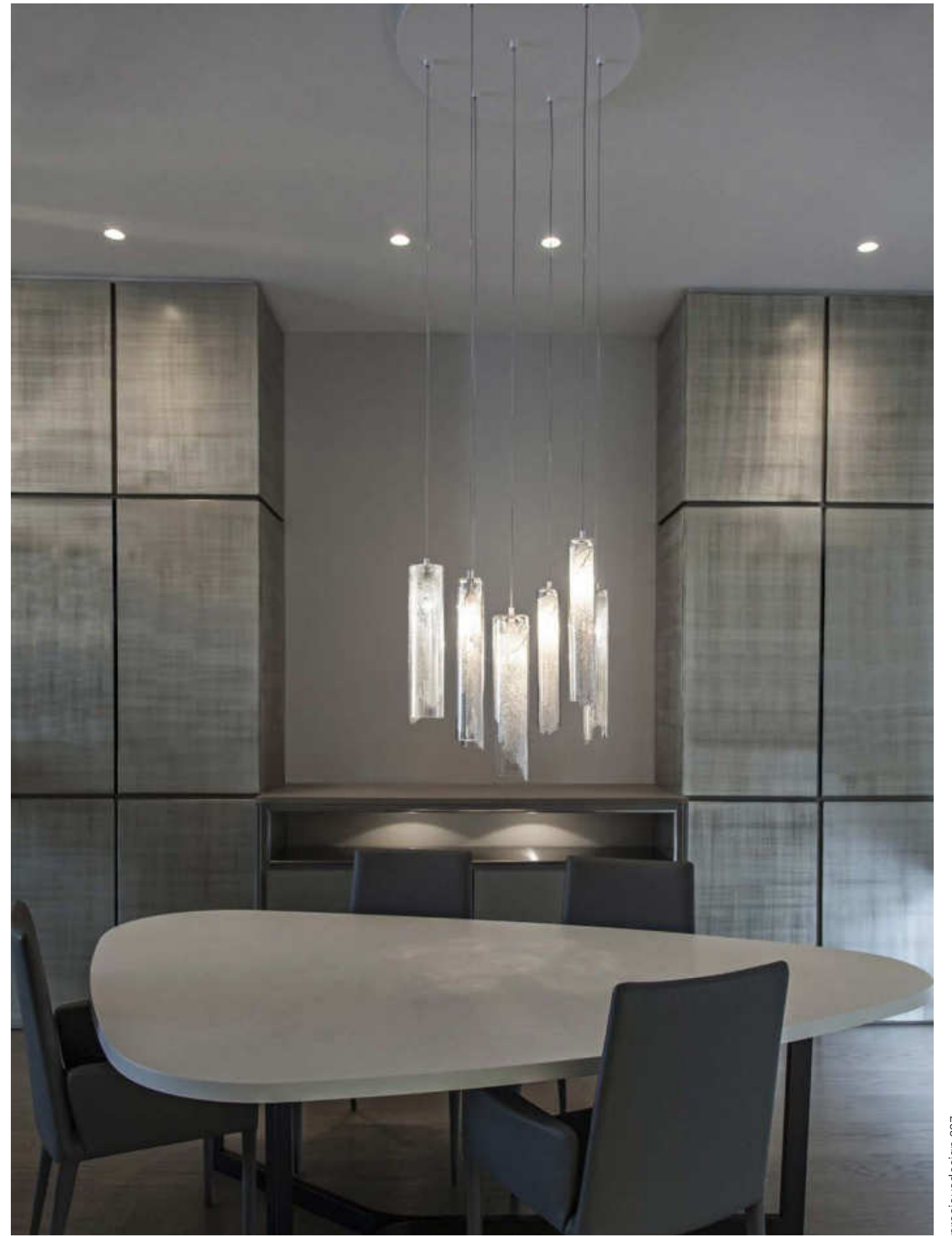



White and clear

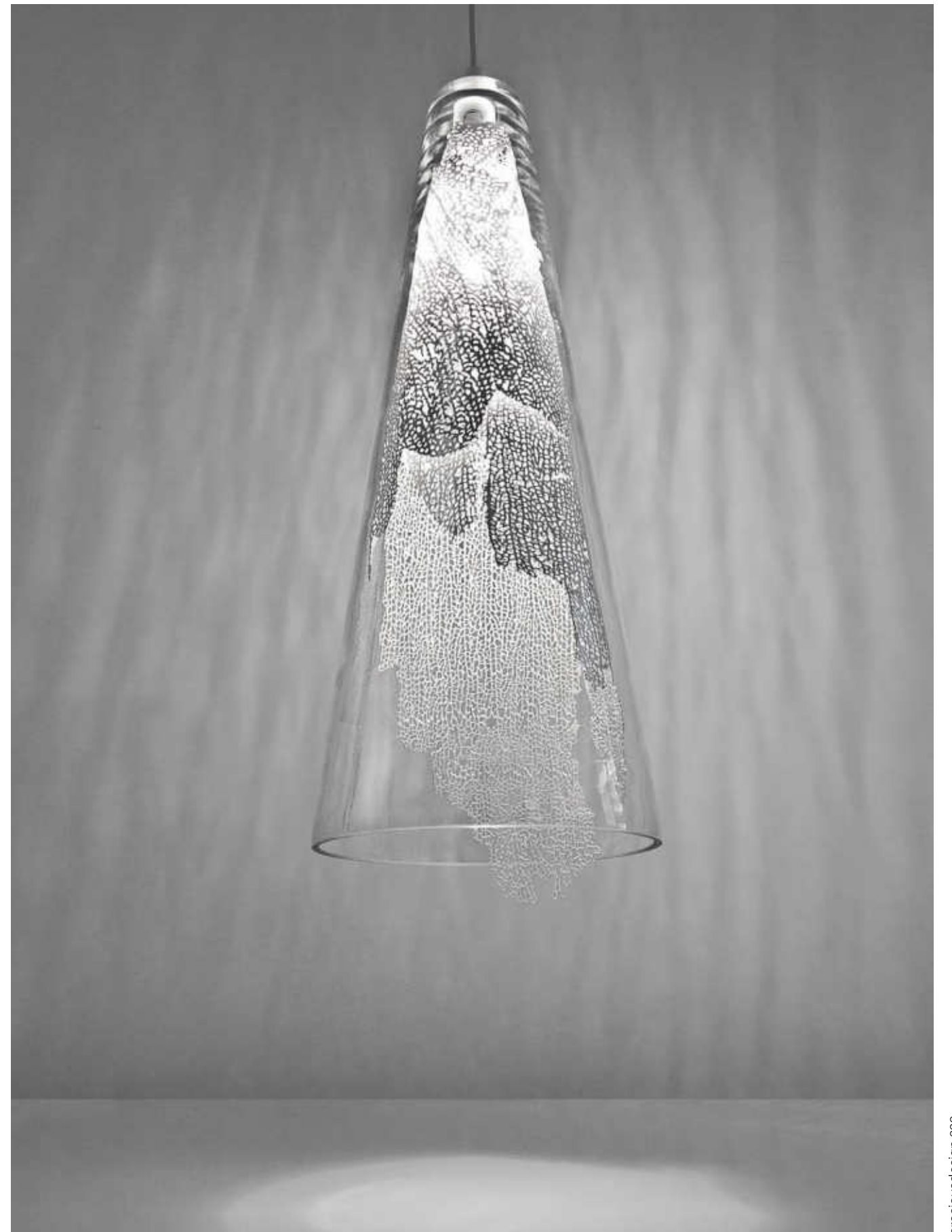

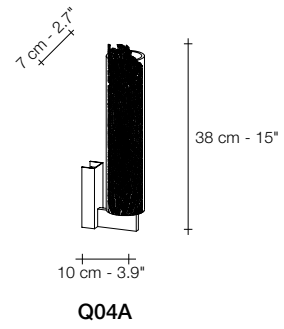
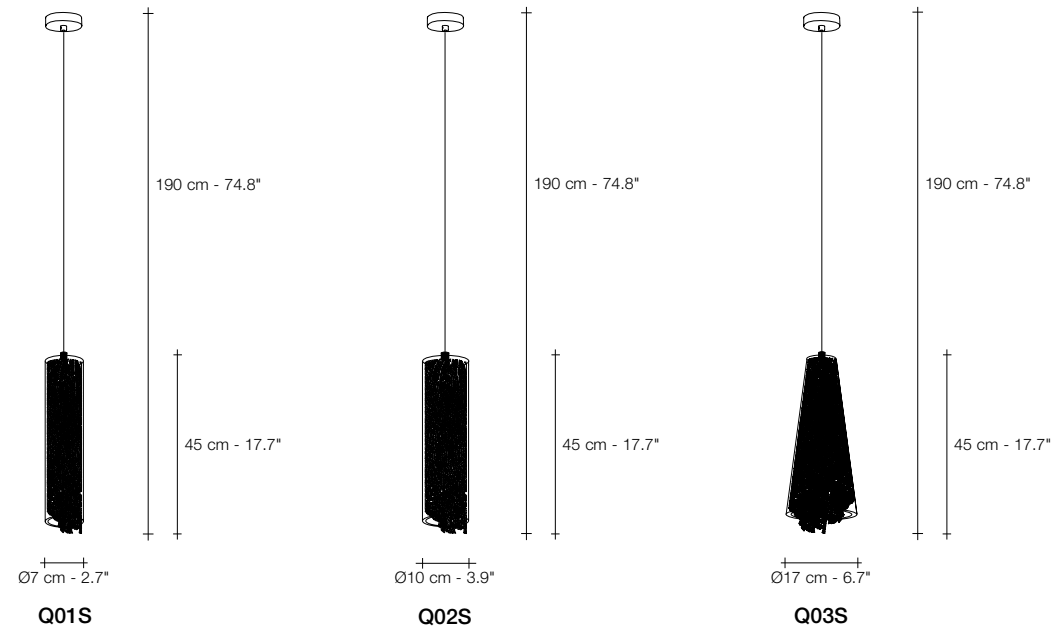

WHITE |
CLEAR GLASS



SILVER PLATED |
CLEAR GLASS



GOLD PLATED |
CLEAR GLASS

LIGHT SOURCE		Q01S	Q02S	Q03S	LIGHT SOURCE		Q04A
230V	E14 LED	4W	4W	4W	230V	G9 LED	3,5W
	Dimmable	✓	✓	✓		Dimmable	✓
120V	E12 LED	4W	4W	4W	120V	G9 LED	4W
	Dimmable	✓	✓	✓		Dimmable	✓



Pug, multum in parvo.

The Pug is a dog described as “much in little,” referring to the greatness of its personality despite its diminutive size. Inspired by the Pug’s charm, designer Jean-François Crochet created Pug pendant light, whose protruding spherical lights are reminiscent of a pug’s face. As with the breed, the Pug pendant packs significant charm and beauty into a small package. Illuminated by led light, these glass pendants are framed by two brass bands. With Pug, it’s easy to bring a new best friend (or pack of friends) into a home. Available in clear/raw brass and satin white/polished brass. Design Jean-François Crochet.





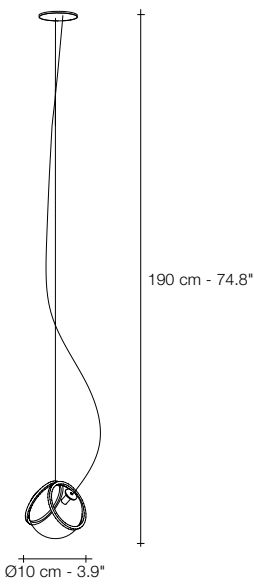

U01S KK
WHITE DISC

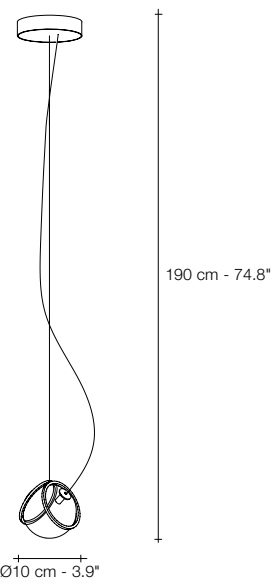

U01S

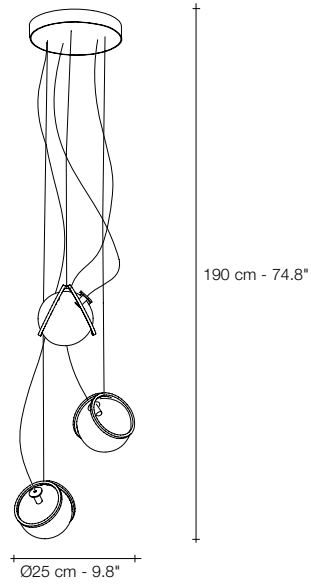

U03S



RAW BRASS |
CLEAR GLASS



POLISHED BRASS |
SATIN WHITE
GLASS

LIGHT SOURCE		U01S KK	U01S	U03S
230V	G4 LED	1,5W	1,5W 3W	3x1,5W
	Dimmable	IGBT 100KΩ 0/1-10V PUSH DALI	IGBT 100KΩ 0/1-10V PUSH DALI	IGBT DALI
120V	G4 LED	1.5W	1.5W	3x1.5W
	Dimmable	ELV	no	ELV

Different dimming options on request.



Anish, playing spoons.

A playful study of reflection, the idea for Anish was born when designer Dodo Arslan, while playing with his daughter, became fascinated by the almost infinite reflections spoons unleashed due to their concave and convex surfaces. Taking this idea to a larger scale, Dodo took inspiration from Italian flatware manufacturer Sambonet and created a pendant composed of a range of spoons, from the smallest teaspoon to serving spoons, which magnify the reflective quality of this shape. The result is an installation that creates a “galaxy” effect of seemingly endless light. Design Dodo Arslan.



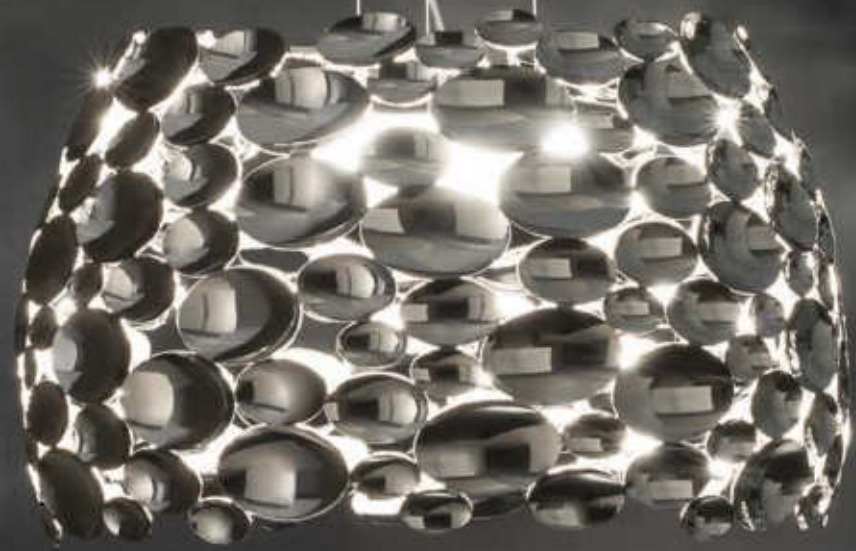

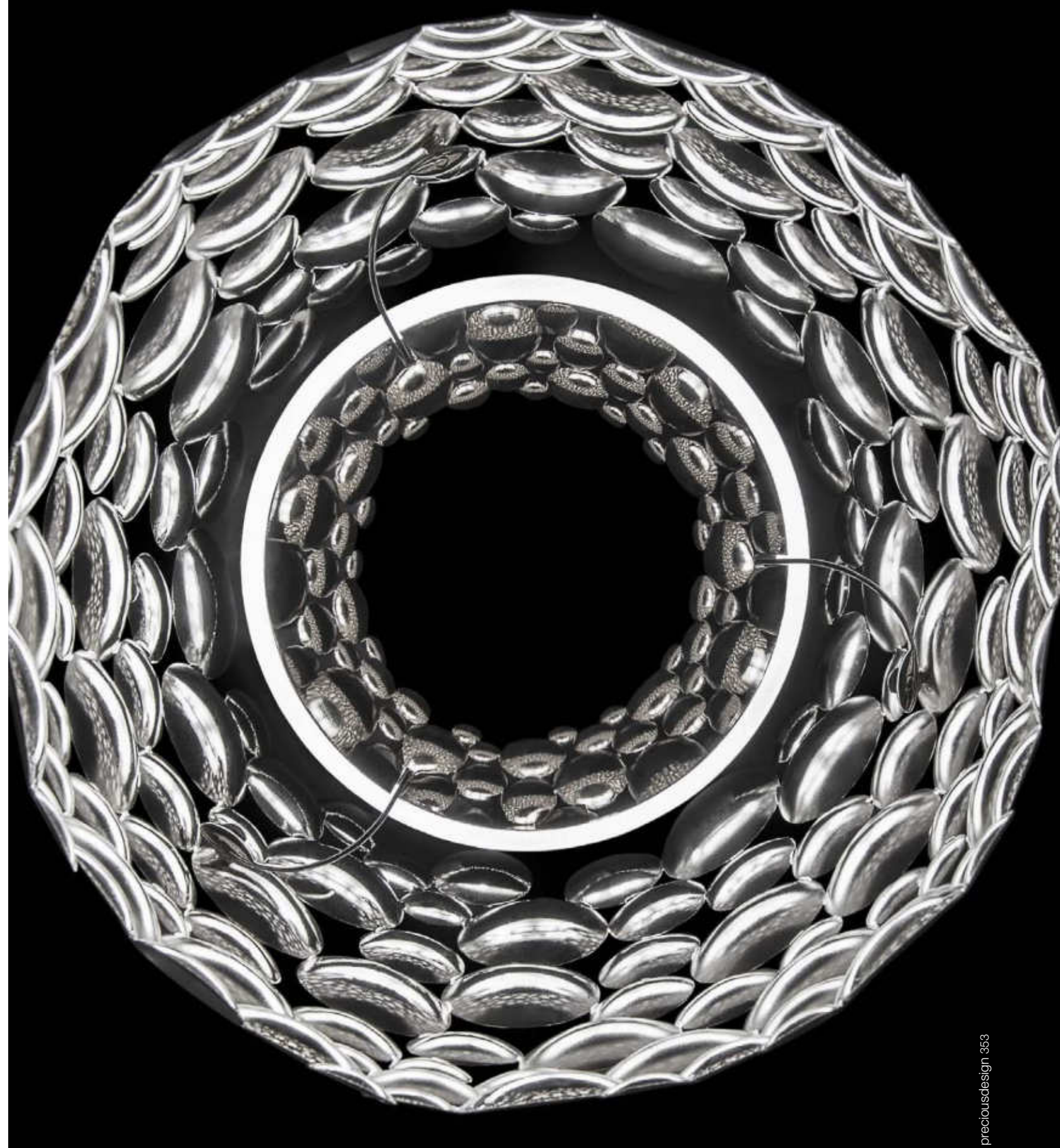

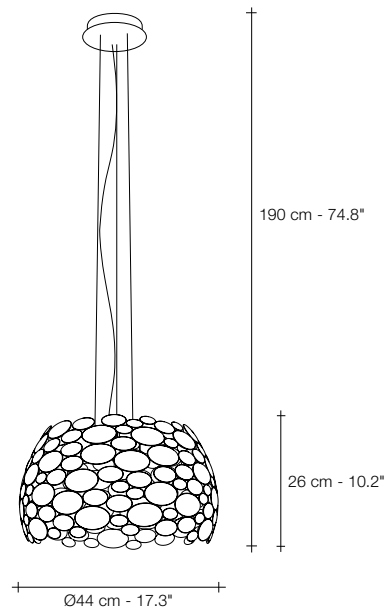

Q61S

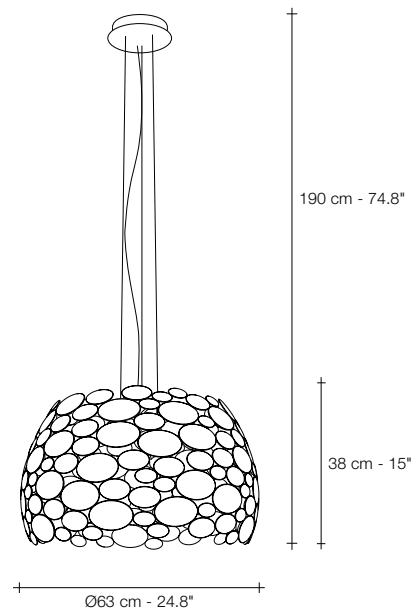

Q62S



NICKEL
PLATED

	Q61S	Q62S
230V	Replaceable LED module CRI 90 3000K 2700K	6x4,5W 3970 lm 3600 lm
	Dimmable	0/1-10V PWM 10-100kΩ PUSH/DALI
120V	Replaceable LED module CRI 90 3000K 2700K	6x4.5W 3970 lm 3600 lm
	Dimmable	1-10V PWM 10-100kΩ

Anish available with integrated LED 3000K or 2700K. Different dimming options on request.



G.r.a., gyrating romantic rings of light.

This clean, precise form is the result of hours of labor by our artisans, who meticulously weld each ring together. G.r.a. is a delicate, refined pendant whose intricate shape belies its romantic glow. Available as an oval or a sphere and finished in nickel, gold plated, or gold leaf, G.r.a. serves as an elegant, unobtrusive complement to any room. Design Bruno Rainaldi.









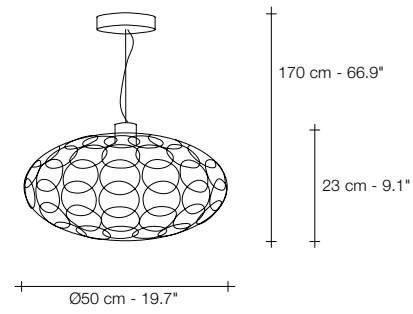

N41S L

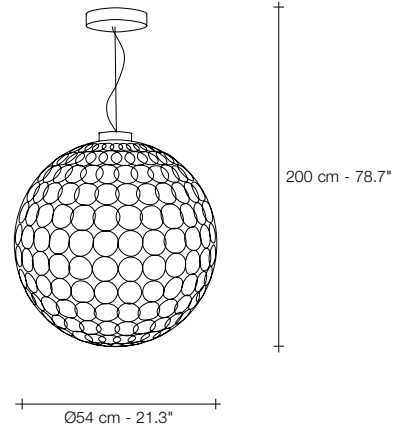

N43S L

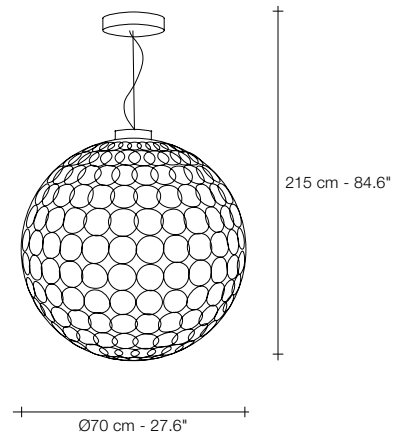

N42S L

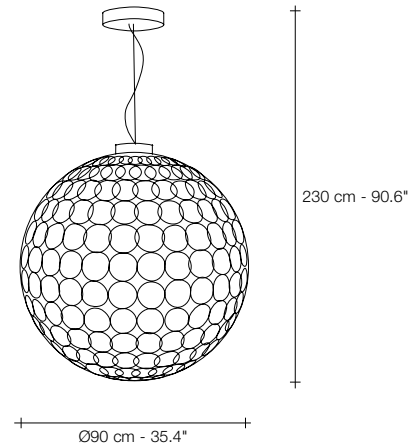

N40S L

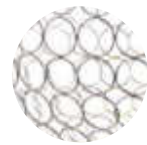

NICKEL PLATED

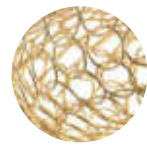

GOLD LEAF

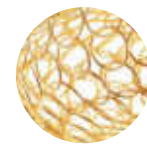

GOLD PLATED

		N41S L	N43S L	N42S L	N40S L	
230V		LIGHT SOURCE	18W	18W	18W	18W
		Replaceable LED module	18W	18W	18W	18W
120V		LIGHT SOURCE	18W	18W	18W	18W
		Replaceable LED module	18W	18W	18W	18W
		CRI 90 3000K 2700K	1640 lm 1570 lm	1640 lm 1570 lm	1640 lm 1570 lm	1640 lm 1570 lm
		Dimmable	1-10V PUSH/DALI	1-10V PUSH/DALI	1-10V PUSH/DALI	1-10V PUSH/DALI

G.r.a. available with integrated LED 3000K or 2700K. Different dimming options on request.



Orten'zia, petals of light.

Recalling the natural beauty of a flower, Orten'zia's hand-soldered "petals" emanate a unique glow, immersing the entire room in a glimmering light. An organic radiance is created through light and shadow, planting a garden within the room. Available in either nickel or gold plated, the Orten'zia's elegant form complements its dramatic light. Design Bruno Rainaldi.







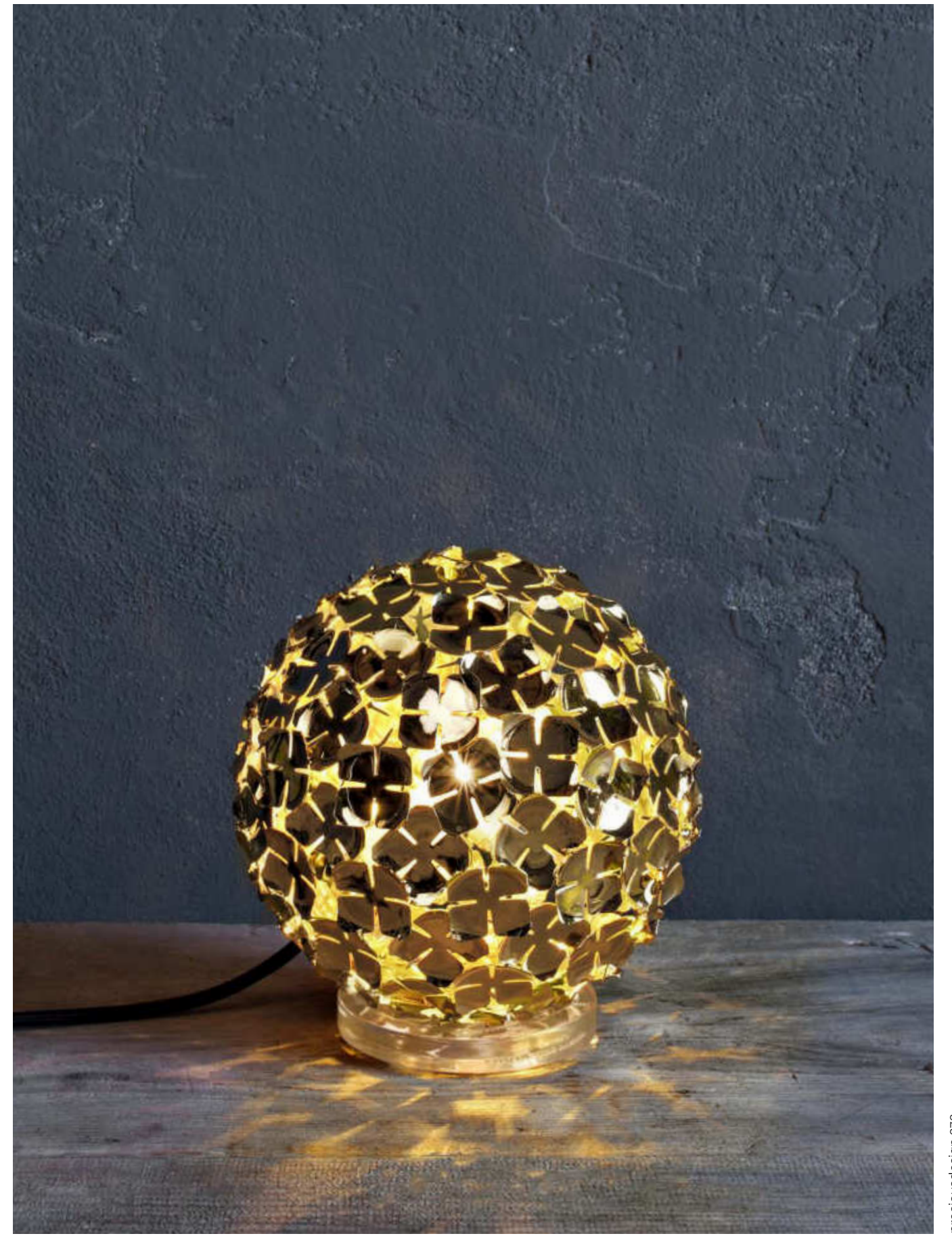

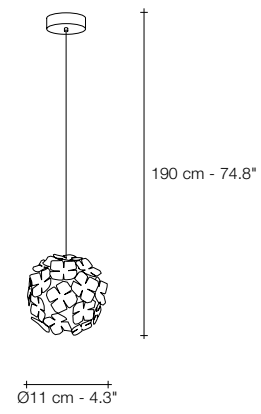

M47S

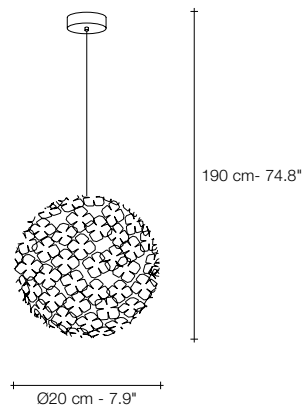

M40S

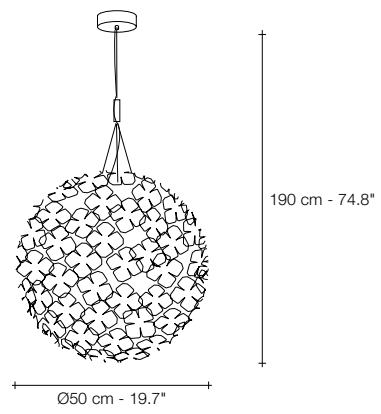

M46S

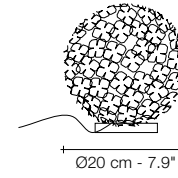

M41B

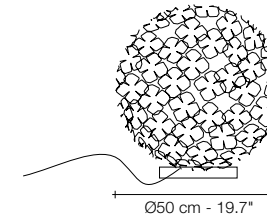

M48P

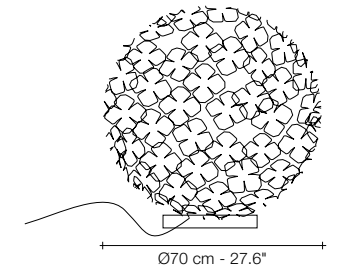

M49P

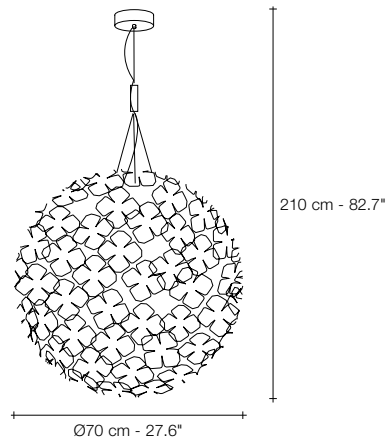

M51S

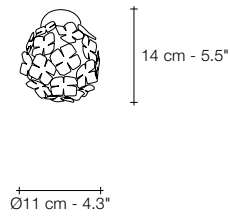

M57L

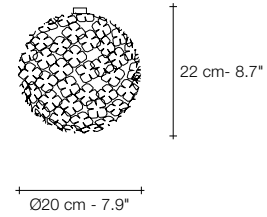

M85L

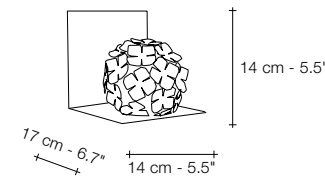

M56A

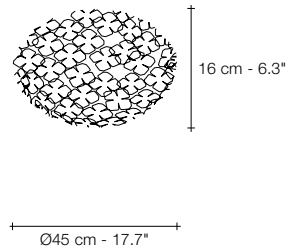

M44L

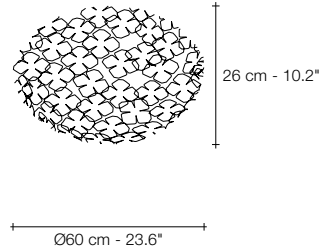

M43L

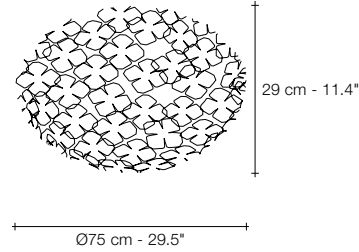

M42L



NICKEL PLATED



GOLD PLATED

	LIGHT SOURCE	M40S	M41B	LIGHT SOURCE	M46S	M43L	M42L	M48P	M49P	LIGHT SOURCE	M44L
230V	E14 LED	4W	4W	E27 LED	15W	11W	15W	11W	15W	R7s HALOGEN	120W
	Dimmable	✓	✓	Dimmable	✓	✓	✓	✓	✓	Dimmable	✓
120V	E12 LED	4W	4W	E26 LED	15W	11W	15W	11W	15W	R7s HALOGEN	150W
	Dimmable	✓	✓	Dimmable	✓	✓	✓	✓	✓	Dimmable	✓

	LIGHT SOURCE	M47S	M57L	M85L	M56A
230V	G9 LED	3,5W	3,5W	4W	3,5W
	Dimmable	✓	✓	✓	✓
120V	G9 LED	4W	4W	5W	4W
	Dimmable	✓	✓	✓	✓

Etoile, twinkling in an indoor sky.

Etoile's intricate network of intersecting nickel lines recalls constellations in a clear night sky. Strategically placed bulbs cast a starry light, twinkling as viewers move around the pendant. By projecting these complex patterns throughout the room, Etoile casts a heavenly glow in any space. Design Christian Lava.







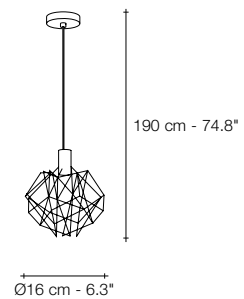

P05S

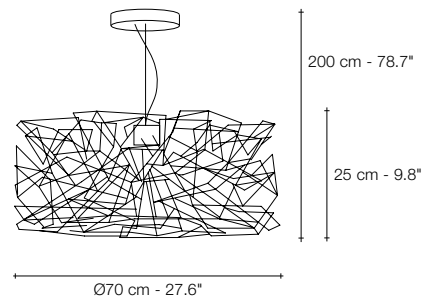

P01S

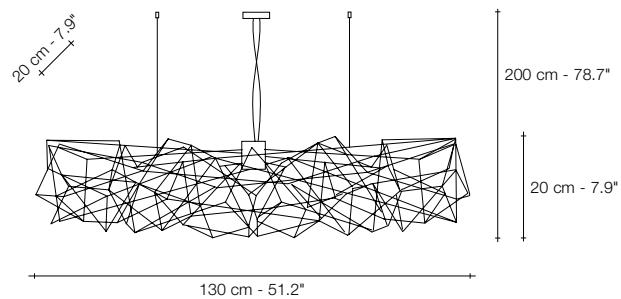

P04S

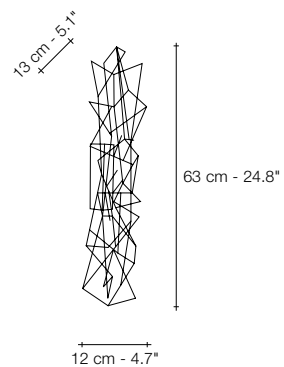

P03A



NICKEL
PLATED

LIGHT SOURCE OPTIONS		P05S	P05S	P01S	P01S	P04S	P04S	P03A
230V	G4 HALOGEN	2W	3W	8x10W	16x1,2W	8x20W	8x2W	6x10W
	G4 LED	20W	10W	8x20W		8x20W	8x2W	6x2W
	Dimmable	IGBT TRIAC	DALI	IGBT TRIAC	0/1-10V 100KΩ PUSH DALI	IGBT TRIAC DALI		IGBT
120V	G4 XENON	20W	-	8x10W	-	8x20W	6x10W	
	G4 LED	2W	-	8x20W	-	8x2W	6x2W	
	Dimmable	ELV	-	IGBT	-	IGBT TRIAC	ELV	

Etoile available with LED light source on request. Different dimming options on request.



Glamour, modern seduction.

Glamour's randomly interspersed rings imbue this design with a seductiveness rarely applied to geometric shapes. The diffused light emanating behind Glamour's rings bathes the surrounding area in a soft, sensuous glow. Available as a wall sconce, ceiling lamp, or pendant, Glamour can provide subtle accents or act as the focal point of a room. Available in nickel and gold plated finishes. Design Dodo Arslan.



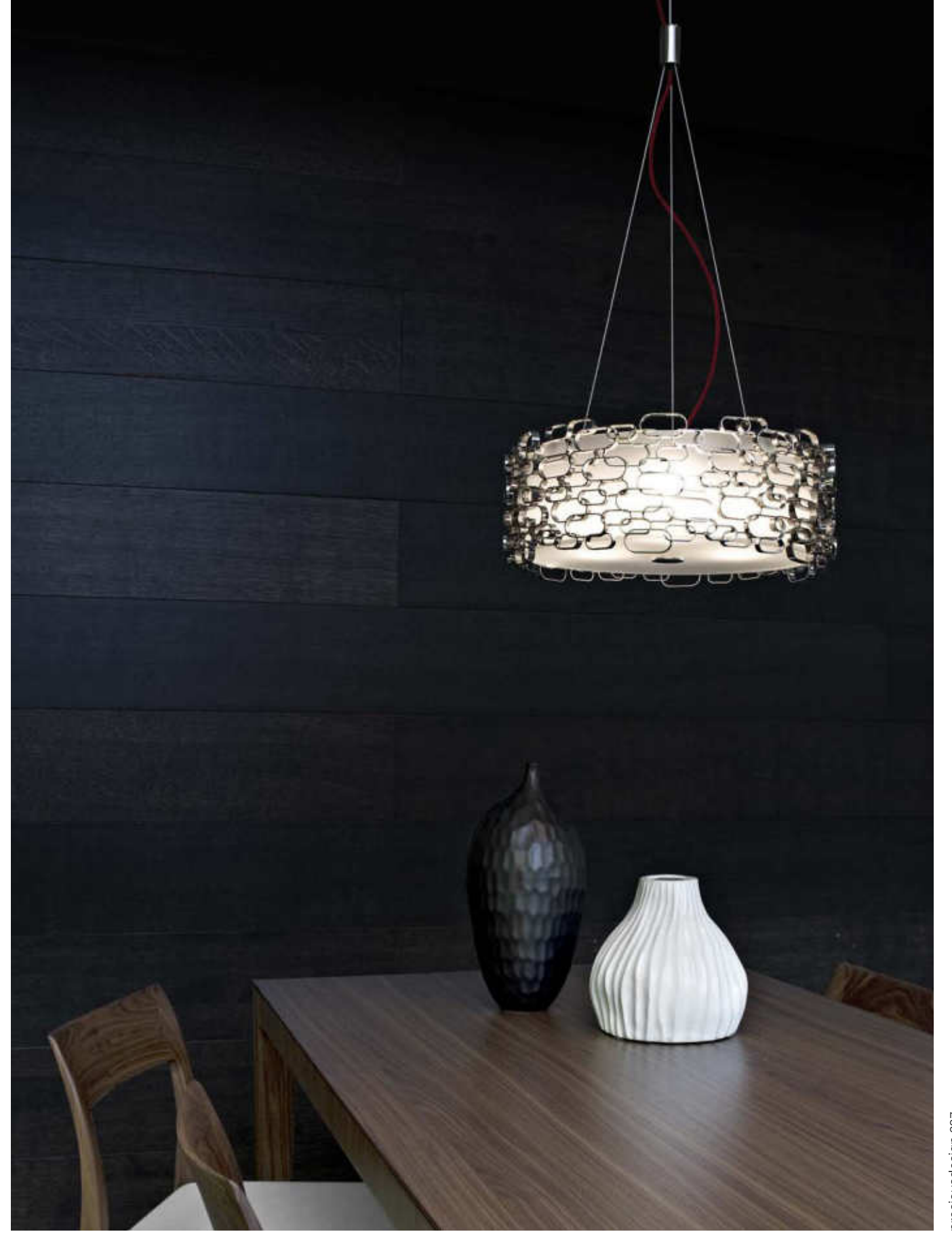



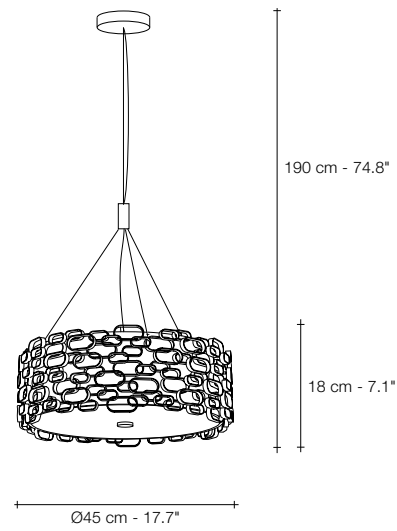

N16S

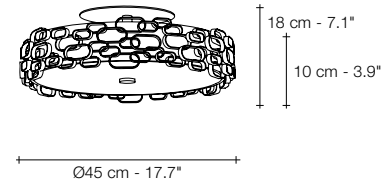

N17L

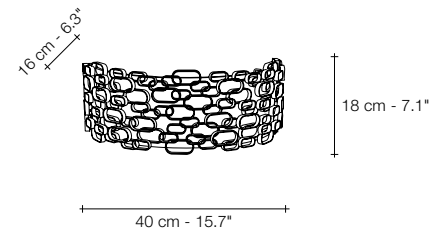

N18A



NICKEL
PLATED



GOLD
PLATED

LIGHT SOURCE		N16S	N17L	LIGHT SOURCE OPTIONS		N18A
230V	E14 LED	3x4W	3x4W	R7s HALOGEN	48W	
	Dimmable	✓	✓	Replaceable LED module 3000K	13W	1025 lm
120V	E12 LED	3x4W	3x4W	R7s HALOGEN	70W	
	Dimmable	✓	✓	Dimmable	IGBT	✓

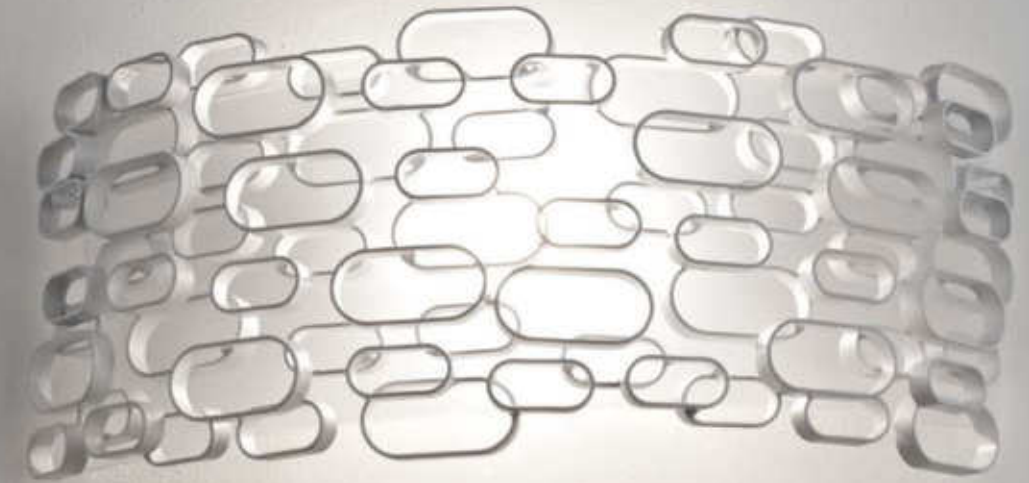

Magdalena, cutting edge beauty.

Reaching inside traditional forms, Magdalena's laser-cut horizontal openings allow its light to expand its range to the entire room. Creating an alluring pattern of light and shadow, Magdalena highlights the shape of the room itself. This unique exchange creates a pendant that impacts every space, regardless of size. Design Bruno Rainaldi.



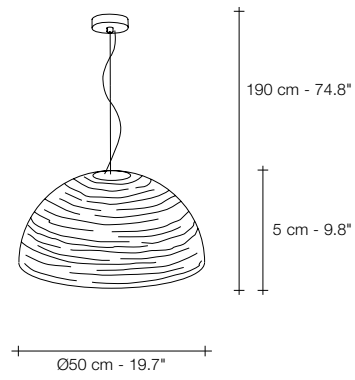

M65S

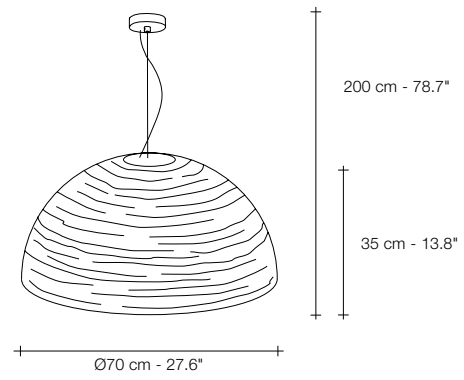

M66S

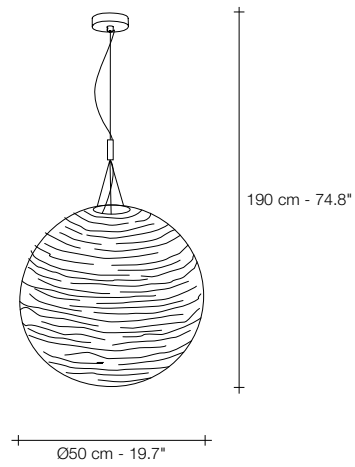

M61S

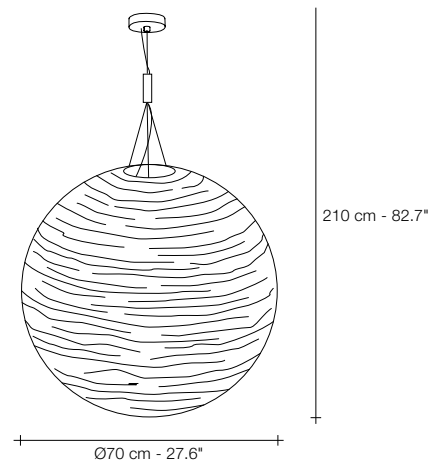

M62S



WHITE



SEMIPOLISHED
NICKEL PLATED

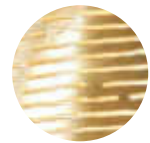

GOLD LEAF

	LIGHT SOURCE	M65S	M66S	LIGHT SOURCE	M61S	M62S
230V	E27 LED globe	15W	15W	E27 LED	15W	15W
	Dimmable	✓	✓	Dimmable	✓	✓
120V	E26 LED globe	15W	15W	E26 LED	15W	15W
	Dimmable	✓	✓	Dimmable	✓	✓



Since the beginning, Terzani has always viewed aesthetics as a way of interpreting natural and artistic beauty. Founded in 1972 in Florence, Italy—the cradle of the Renaissance—the company was compelled to follow the creative invocations of the city. The word “aesthetics” originates from the Greek “aisthesis,” which means “feeling” or, more precisely, knowledge created by the use of one’s senses. When you look at a Terzani design, you can sense how its light enchantingly envelops the surrounding space. It’s more than simply a practical, utilitarian design; it’s an aesthetic that represents modern and artistic beauty through the use of design and innovative technologies.

Intersection of art, luxury and design

Terzani creations are always inspired by the dialogue between the company and the designers themselves. The pieces are born from a compelling feeling that Nicolas articulates to his designers. This inspiration can be a shape that exists in nature, as seen with the fish that inspired “I Lucci Argentati,” the stones or drops of water that inspired “Mizu,” or a material or working method that attracts his attention. With the team of designers who work with the company, a project will be executed with all the necessary technical diligence, but the starting point that defines any Terzani light is always a feeling.

To create a style like the one we at Terzani have established, you need to balance several characteristics. Terzani is elegant and sophisticated, innovative yet original. It uses the latest technology, but also incorporates fine materials crafted in a very artisan way. Each lamp is an object or sculpture meant to be fully integrated into its surroundings, spreading a charming and enchanting play of light. This creates an ever-changing dialogue between the lamp and the space around it. The feeling that Terzani exudes is one of harmony and togetherness. Its products are grounded in the human process, transmitting the handmade artisan traditions of lovingly crafting objects piece by piece. This is the essence of Terzani, which sees beauty in the contemporary world, tradition, and the search for new forms and languages. Terzani continues to redefine the way luxury lighting is designed and produced. Through experimentation with new production methods and forward-thinking ideas, it has become known for designs that use sculpture, light, shadow, and motion to reshape spaces.

These handmade products sit at the intersection of art, luxury, and design. Following Terzani’s artisan tradition, each “lighting sculpture” continues to incorporate traditional methods of processing glass and metal, along with giving individual attention to every detail.

These designs are brought forth through the dialogue between Terzani and some of the world’s most renowned designers. Terzani is proud to work with such talented artists as Dodo Arslan, Barlas Baylar, Jean-François Crochet, Nicolas Terzani, Nigel Coates, Christian Lava, Studio 14, Draw, Simone Micheli, Stefano Papi & Saviz Yaghmai, and others, to create the company’s original style.

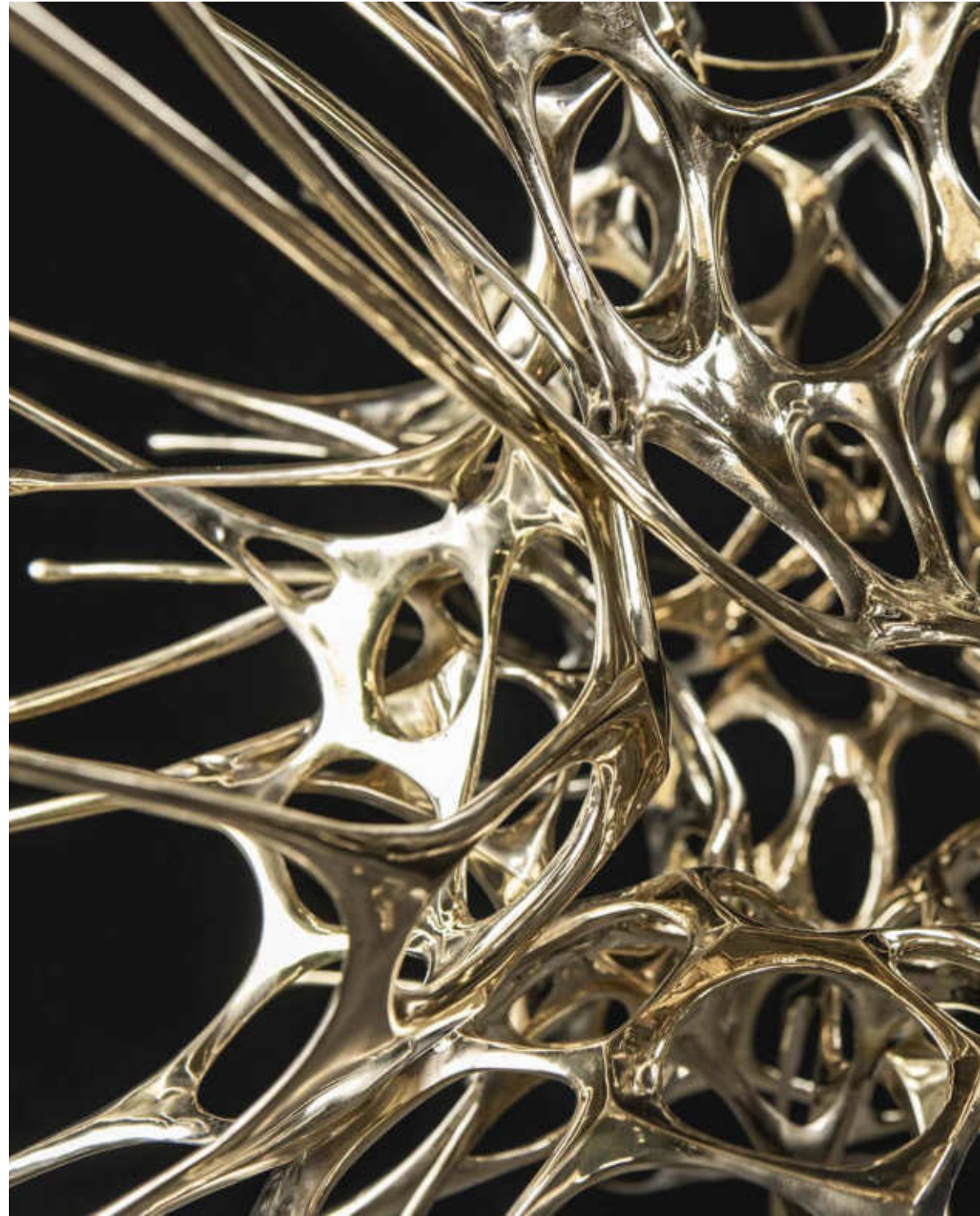

TERZANI
LA LUCE PENSATA

All products in the Terzani collections are inspired by a return to noble artisan traditions. Every object is carefully created using craft techniques, and for this reason, certain details may vary from product to product. These variations are not imperfections but characteristic peculiarities of the production process. Terzani reserves the right to modify its products in order to improve their features. Product reproduction on paper may result in a misrepresentation of some colors. For updated technical data and ETL listing information, please refer to our current price list or spec sheets available at terzani.com. For information about Patent & Design Registration, please visit: www.terzani.com/patents.

Creative Direction Nicolas Terzani
Art Direction Camilla Cordella
Photos Leonardo Beglieri
Digital imaging Fulvio Gallotti
Printed on FSC eco-friendly paper
Special thanks to |
Minotti Firenze By Belvedere
Flair Firenze
La ménagère Firenze

Eu (Italy) 2024

© terzani 2024



**Headquarter & Showroom
Terzani srl**

Via Castelpulci Int.9
50018 Scandicci Firenze Italy
Office +39 055 722021
Showroom +39 345 2942079
info@terzani.com

**Headquarter USA & Showroom
Terzani USA, Inc.**

2501 SW 56th Ave
Pembroke Park FL 33023
Office 954 438 7779
Toll free1 866 380 5412
Showroom +1 954 842 1259
info@terzaniusa.com

terzani.com



TERZANI
LA LUCE PENSATA

terzani.com