

BRANDVAN
® **EGMOND**



2025

Welcome...

William Brand (1963) - an award-winning architect and sculptor - is widely recognised for his imaginative and daring sculptural lighting.

In 1989, he founded his own atelier Brand van Egmond to create without restraint. His lighting sculptures, often perceived as art pieces, grace the finest residences, exclusive boutiques, stunning hotels and leading art exhibitions.

We welcome everybody who wants to see our designs, or would like personal advice from William Brand and his team, to our office and atelier in Naarden, The Netherlands.

www.brandvanegmond.com



BRAND VAN EGMOND





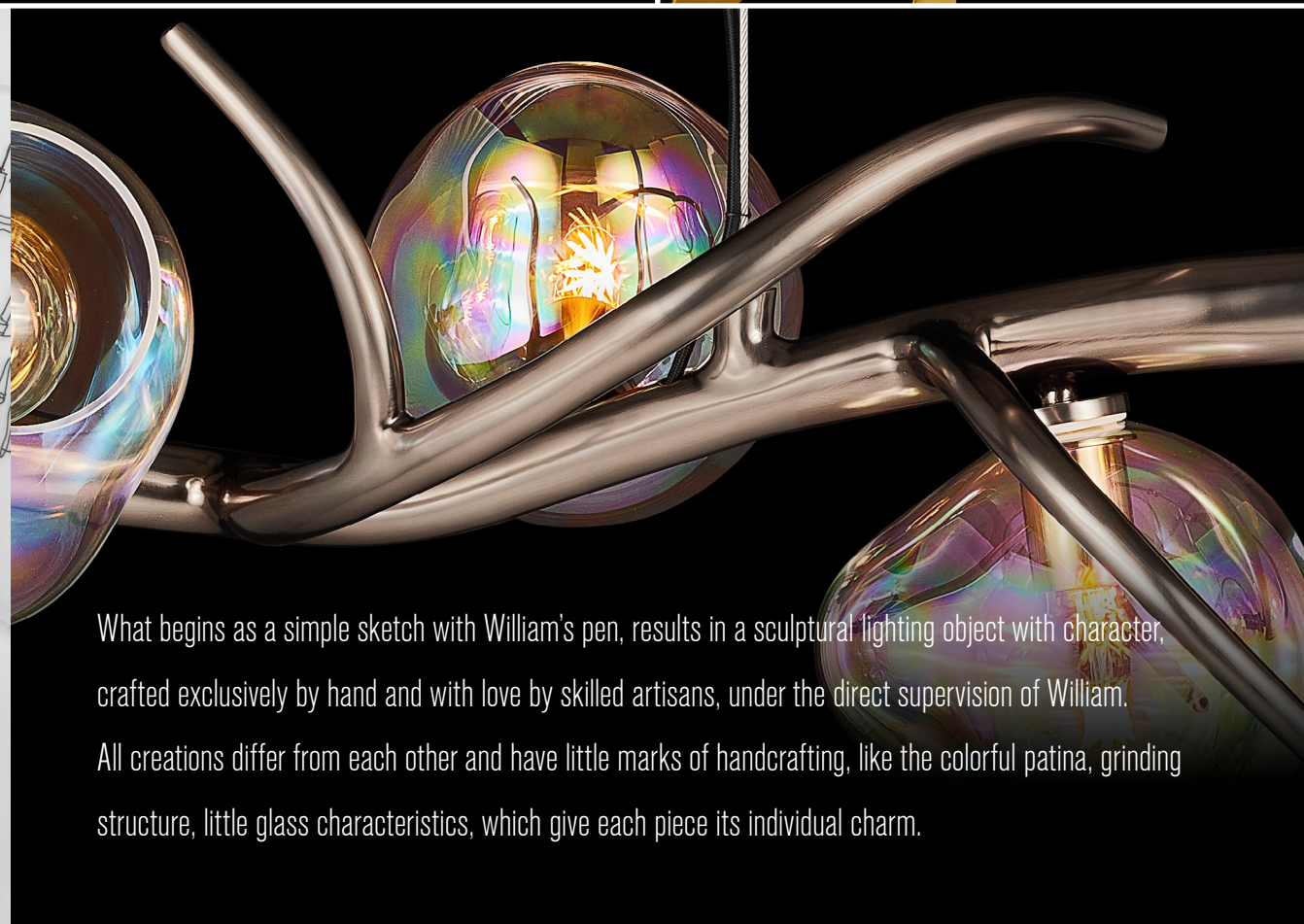
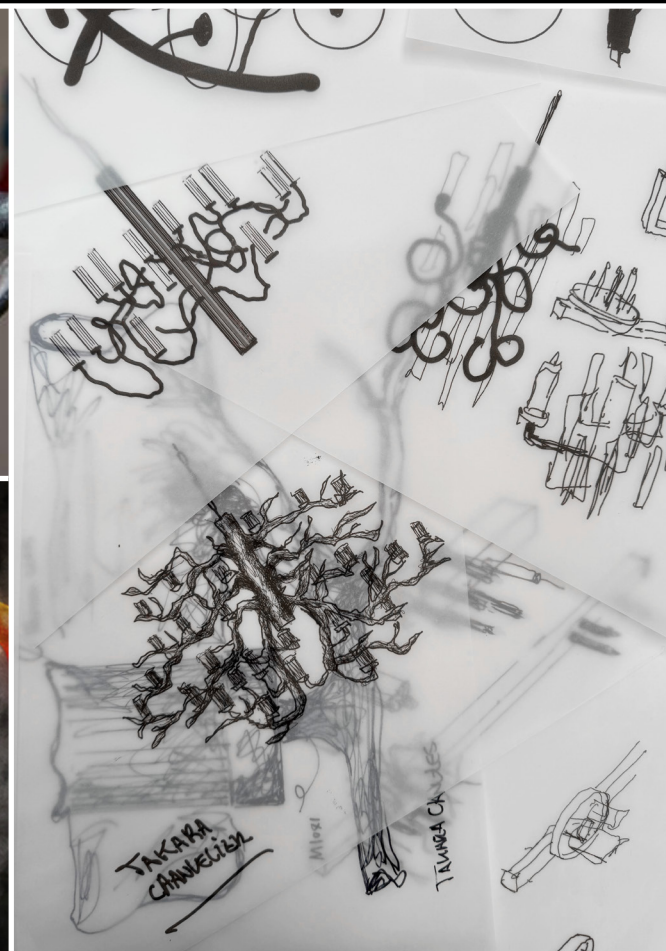







"Every design of new collections follows the same sequence. After the first sketches, I quickly move towards the atelier and start working with new materials and shapes by myself. Of every collection I can still feel every curve and twist literally in my hands." - William Brand.



What begins as a simple sketch with William's pen, results in a sculptural lighting object with character, crafted exclusively by hand and with love by skilled artisans, under the direct supervision of William. All creations differ from each other and have little marks of handcrafting, like the colorful patina, grinding structure, little glass characteristics, which give each piece its individual charm.

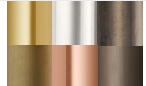

Table of Contents

	Collection	Images	Technical info
	SALSA	08-15	47
	BLOSSOM	16-25	48-50
	BUBBLES TWILIGHT	26-27	51
	SOIRÉE	28-29	52
	ORPHEUS CHANDELIER	30-33	53
	TAKARA CANDLES	34-39	54-55
	FOUNDER AND DESIGNER WILLIAM BRAND	40	
	OPTIONAL FINISHIES	43	
	CERTIFICATE	44	
	TECHNICAL INFORMATION	46	
	GENERAL TERMS AND CONDITIONS	56	



Salsa

Design by William Brand

The poetry of motion, written in light, defines the Salsa collection.

Lyrical, thin lines move in effortless harmony, transforming untamed chaos into rhythmic dance and light. With every turn, the Salsa flows in fluid, dynamic circles—ever evolving.



SALC100GSF

Salsa Chandelier Round

Ø100xH.55 cm, 16x G9, 21 kg, gold satin finish

Technical details page 47



SALC100GSF

Salsa Chandelier Round

Ø100xH.55 cm, 16x G9, 21 kg, gold satin finish

Technical details page 47



SALC120BL

Salsa Chandelier Round
Ø120xH.70 cm, 24x G9, 31kg, black high gloss finish
Technical details page 47



SALC120BL

Salsa Chandelier Round
Ø120xH.70 cm, 24x G9, 31 kg, black high gloss finish
Technical details page 47



SALSA CHANDELIER ROUND
silver satin finish



SALSA CHANDELIER ROUND
gold satin finish



SALC70SSF

Salsa Chandelier Round
Ø70xH.55 cm, 12x G9, 10 kg, silver satin finish
Technical details page 47



SALC70SSF

Salsa Chandelier Round
Ø70xH.55 cm, 12x G9, 10 kg, silver satin
Technical details page 47



Blossom

Design by William Brand

The strength of the smallest seed to awaken underground, reach through darkness, and blossom. This collection embodies the power of transformation and growth. The mystery of life, distilled to its essence.

With the Blossom collection, the soft light creates harmony and serenity, balancing beauty with calm. A flower flourishes, symbolising life's purest transformation.



BLOC90BDP-GLSAT

Blossom Chandelier Round

Ø90xH.75 cm, 5x E14, 18 kg, bronze dark patina finish, glass satin

Technical details page 48



BLOC90BDP-GLGB

Blossom Chandelier Round

Ø90xH.75 cm, 5x E14, 18 kg, bronze dark patina finish, glass in grey shades finish

Technical details page 48



BLOOBJ130BDP-GLSAT

Blossom Sculptural Object

L.130xW.115xH.105 cm, 10x E14, 34 kg, bronze dark patina finish, glass satin

Technical details page 49



BLOOBJ130BDP-GLSAT

Blossom Sculptural Object

L.130xW.115xH.105 cm, 10x E14, 34 kg, bronze dark patina finish, glass satin

Technical details page 49



BLOSSOM SCULPTURAL OBJECT

bronze dark patina finish, glass in grey shades



BLOOBJ130BDP-GLGB

Blossom Sculptural Object

L.130xW.115xH.105 cm, 10x E14, 34 kg, bronze dark patina finish, glass in grey shades

Technical details page 49



BLOSSOM CHANDELIER VERTICAL
silver satin finish, glass in grey shades



BLOV200SSF-GLGB

Blossom Chandelier Vertical

L.80xW.70xH.200 cm, 10x E14, 34 kg, silver satin finish, glass in grey shades

Technical details page 50



BLOSSOM SCULPTURAL OBJECT
bronze dark patina finish, glass satin



BLOV200SSF-GLSAT

Blossom Chandelier Vertical

L.80xW.70xH.200 cm, 10x E14, 34 kg, silver satin finish, glass satin

Technical details page 50



Bubbles Twilight

Design by William Brand

Our free-flowing Bubbles have matured into alluring shades of grey. From playful pleasure to the graceful beauty of aging, time reveals its true elegance.

A beautiful dance of light and shadow as the sun sets: the Bubbles Twilight is bold enough to capture attention, yet gentle enough to let the light whisper.



BUBTC100BDP

Bubbles Twilight Chandelier Round

Ø100xH.70 cm, 7x E14, 22 kg, bronze dark patina finish

Technical details page 51



BUBTC100BDP

Bubbles Twilight Chandelier Round

Ø100xH.70 cm, 7x E14, 22 kg, bronze dark patina finish

Technical details page 51





Soirée

Design by William Brand

The table where laughter flows, glasses are raised, and stories unfold is the heart of every gathering. A place of warmth and welcome. Soirée captures this very essence, bringing the magic of candlelight and companionship into the heart of your home.

As the evening unfolds, the gentle flicker of candles marks the passing of time, their soft glow shifting and changing, just like the conversations around the table. More than just illumination, Soirée is a celebration of evenings shared, memories made, and of light that keeps the moment alive.



SOEHL160BLM-TRGC

Soirée Hanging Lamp Long

L.160xW.25xH.32 cm, 3x GU10 spot downlight + 9x G9, 15 kg,
black matt finish with gold colour tray
Technical details page 52

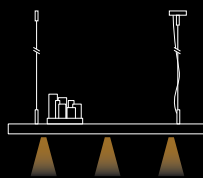

Tabletop enlightened by hidden
3x GU10 7,5 watt/ 390 - 455 lm downlights



SOEHL160BLM-TRN

Soirée Hanging Lamp Long

L.160xW.25xH.32 cm, 3x GU10 spot downlight + 9x G9, 15 kg,
black matt finish with nickel tray
Technical details page 52

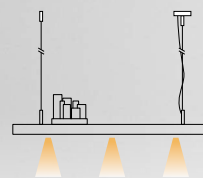

Tabletop enlightened by hidden
3x GU10 7,5 watt/ 390 - 455 lm downlights





Orpheus Chandelier

Design by William Brand

The Orpheus, with its stunning collection of minerals and hand-selected gemstones, has evolved into a breathtaking centrepiece. Rooted in its earthy origins, it now embraces an even more evocative design.

Each carefully selected stone tells a unique story of Earth's treasures, while refined craftsmanship elevates it to a masterpiece. A true testament to the raw power and subtle grace of nature's rare gems, the Orpheus Chandelier transforms any space with its natural beauty and sculpted allure.

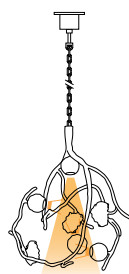

Tabletop enlightened by hidden
1x GU10 7,5 watt/ 390 - 455 lm downlight

ORC65BDP-MAL

Orpheus Chandelier Round

Ø65xH.80 cm, 4x GU10 spot light, 12 kg, bronze dark patina finish with malachite

Technical details page 53

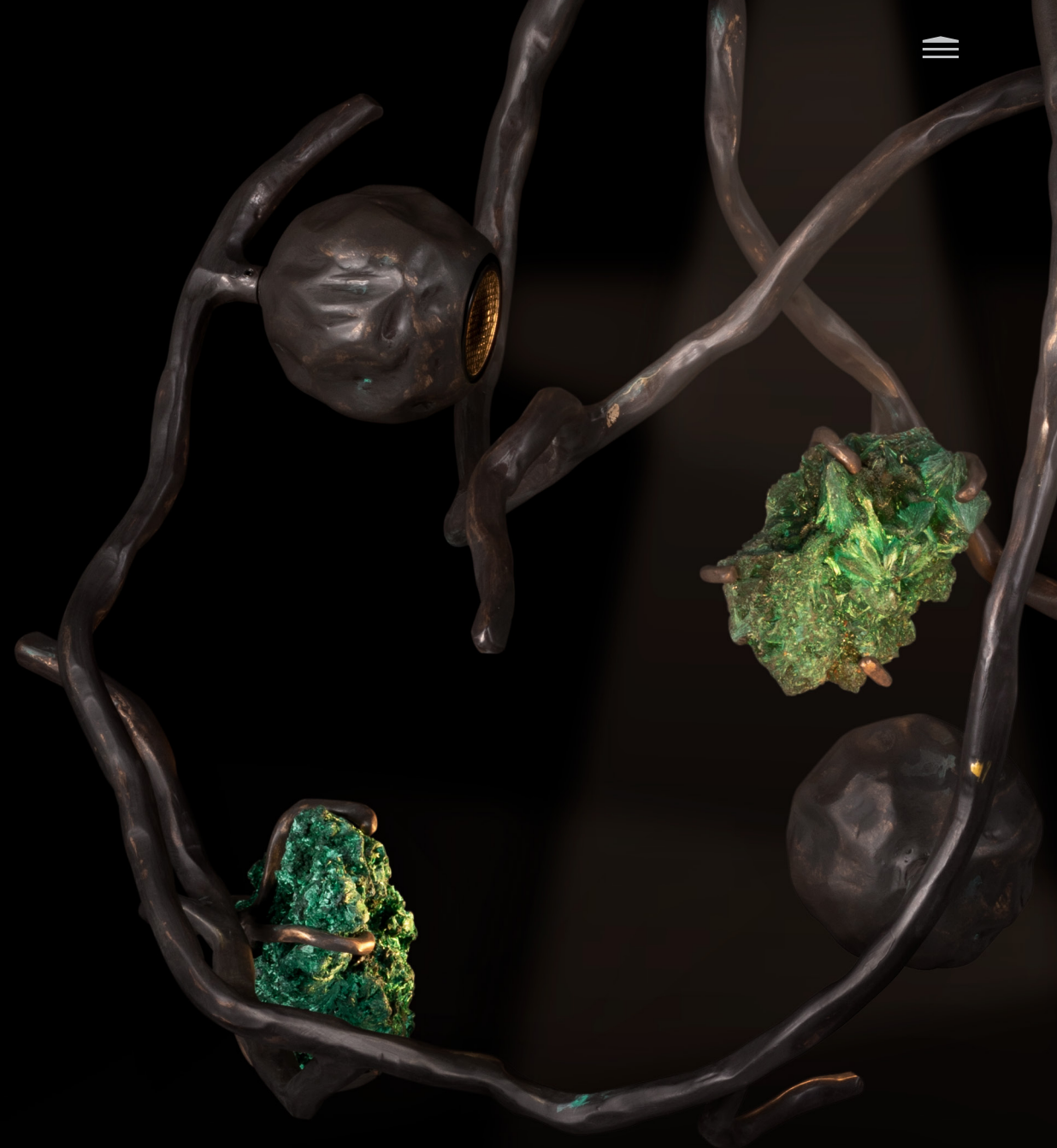

ORPHEUS CHANDELIER ROUND
bronze dark patina finish with malachite

Tabletop enlightened by hidden
1x GU10 7,5 watt/ 390 - 455 lm downlight



ORC65BDP-MAL

Orpheus Chandelier Round
 Ø65xH.80 cm, 4x GU10 spot light, 12 kg, bronze dark patina finish with malachite
 Technical details page 53

Tabletop enlightened by hidden
 1x GU10 7,5 watt/ 390 - 455 lm downlight



Customised ORPHEUS

Element
 Ø50xH.140 cm, 1x GU10 spot downlight, 13 kg, bronze dark patina finish

Tabletop enlightened by hidden
 1x GU10 7,5 watt/ 390 - 455 lm downlight

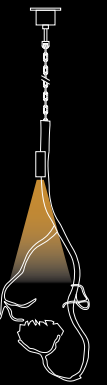



Takara Candles

Design by William Brand

Washed ashore, weathered and worn by time, the Takara Candles are a testament to Nature's raw beauty.

Sculpted to last for generations, each Takara, Japanese for treasure, embodies the artistry of craftsmanship and the quiet strength of the Earth's forces.



SPTAKCC100GL

Takara Candles Chandelier Round in customised finish
Ø100xH.40 cm, 10x G9, 15 kg, gold leaf finish
Technical details page 54



TAKCHL140N

Takara Candles Hanging Lamp Long
L.140xW.40xH.30 cm, 3x GU10 spot downlight + 6x G9, 15 kg, nickel finish
Technical details page 55

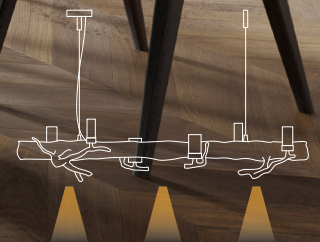

Tabletop enlightened by hidden
3x GU10 7,5 watt/ 390 - 455 lm downlights



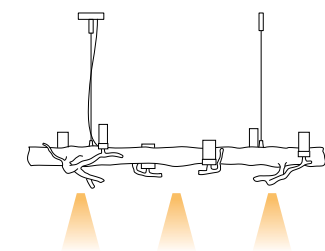

Tabletop enlightened by hidden
3x GU10 7,5 watt/ 390 - 455 lm downlights

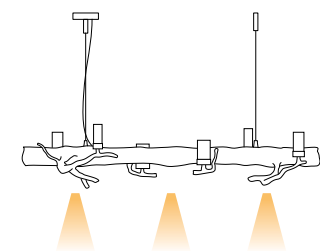

Tabletop enlightened by hidden
3 - 4x GU10 7,5 watt/ 390 - 455 lm downlights

TAKCHL140N

Takara Candles Hanging Lamp Long

L.140xW.40xH.30 cm, 3x GU10 spot downlight + 6x G9, 15 kg, nickel finish

Technical details page 55

TAKARA CANDLES HANGING LAMP LONG

bronze dark patina finish



TAKCHL160BDP

Takara Candles Hanging Lamp Long

L.160xW.40xH.30 cm, 3x GU10 spot downlight + 6x G9, 17 kg, bronze dark patina finish

Technical details page 55

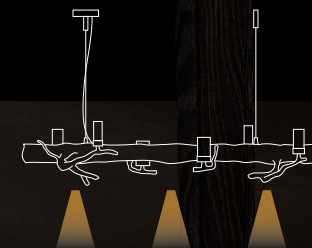

Tabletop enlightened by hidden
3x GU10 7,5 watt/ 390 - 455 lm downlights

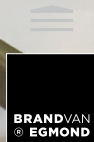
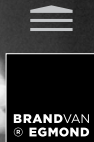

William Brand

founder / designer

William Brand – an award-winning designer, sculptor - is widely recognised for his imaginative and daring sculptural lighting. He was trained as an artist and an architect. He graduated at the academy of fine arts and design. His lighting sculptures, often perceived as art pieces, grace the finest residences, exclusive boutiques, stunning hotels and leading art exhibitions.

His interior designs are minimalist, in contrast to his lighting designs which have a powerful sculptural presence. His way of working is quite specific. Immediately after defining the concept he starts working like a sculptor; experimenting and crafting while having the object sculpting in his hands, often with unexpected results. Therefore the journey is just as exciting and important as the destination.

Optional finishes

Architects and other co-creatives are invited to discover the endless possibilities of customising our lighting sculptures.

We hope to inspire you through the different colours and forms of various compositions, just as we enjoy being stimulated by your requests. William Brand's background in architecture gives him the insight to fully understand the demands and challenges of your work. Combined with his experience, he is the perfect partner to translate your needs into handcrafted reality.

For our clients, we not only customise to different dimensions but also in different finishes, allowing for a truly personal lighting sculpture to be created.



				
001 Nickel (N)*	002 Black Matt (BLM)	003 Black High Gloss (BL)	004 White Matt (WM)	005 White High Gloss (W)
				
008 Bronze (B)	010 Brass High Gloss (BR)* for KELP only	011 Stainless Steel (ST)	012 Brass Aged (BRA)*	013 Copper High Gloss (COP)*
				
015 Silver Colour leaf (SL)	016 Gold Colour leaf (GLR)	017 Brass Grinded (BRG)*	019 Brass Burnished (BRBUR)*	019 Brass Burnished (BRBUR)* with nano wax coating
				
020 Copper Burnished (COPBUR)*	020 Copper Burnished (COPBUR)* with nano wax coating	021 Gold Colour (GC)	022 Nickel Aged Cool (NAC)*	023 Brass Aged Colour (BRAC)*
				
024 Gold Satin (GSF)	025 Copper Satin (COPSF)	026 Nickel Aged Warm (NAW)*	027 Bronze Dark Patina (BDP)*	028 Silver Satin (SSF)

*Due to the unique finishing process, particularly all variations of Nickel, Brass, Copper, and Bronze Dark Patina finishes, lights intended for the same space should be ordered at the same time to ensure a consistent appearance.

Finish colours may vary slightly when viewed in print or on screens.

Certificate



Technical information

Each BRAND VAN EGMOND lighting sculpture is issued with a certificate of authenticity and registered with a unique number.

This guarantees that you are in possession of an original BRAND VAN EGMOND object.

We advise you to keep this certificate together with your receipt of purchase in a safe place.

General information



CUSTOMISATION

Brand van Egmond lighting sculptures can be customised to almost any size and finish, perfectly tailored to elevate each interior with timeless allure.

CEILING COVERS | SUSPENSION

All lights are supplied with standard ceiling covers matching the specific models. Customisation can be made upon request.

LIGHT BULBS AND COMPATIBILITY WITH BUILDING ELECTRICAL SYSTEMS

Every lighting sculpture is supplied with a set of complimentary plug-and-play, dimmable retrofit LED light bulbs. These bulbs are easy to replace when needed and available at your local webshop supplier. They operate without build-in drivers, transformers, or dimmers and are compatible with phase-cut dimmers and popular dimmer systems like DALI. Only our floor and table lamps feature integrated LED dimmers on their cables.

Brand van Egmond does not produce or sell light bulbs. Instead, we carefully select high-quality options from trusted external suppliers. Please note that the atelier is not responsible for the quality or performance of light bulbs and cannot address any related complaints.

For detailed information on voltage, wattage, and socket base specifications for individual models, please refer to the technical details provided for both lamps and their light bulbs.

The compatibility of lights with your building's control systems must be verified and confirmed by a qualified electrician, including any terms and conditions for integration.

INSTALLATION GUIDES, CLEANING AND MAINTENANCE INSTRUCTIONS

All lights are supplied with dedicated installation guides.

All documents will be available at: www.brandvanegmond.com/downloads/



Collection Salsa

Images of the collection: pages 08-15

Chandelier Round

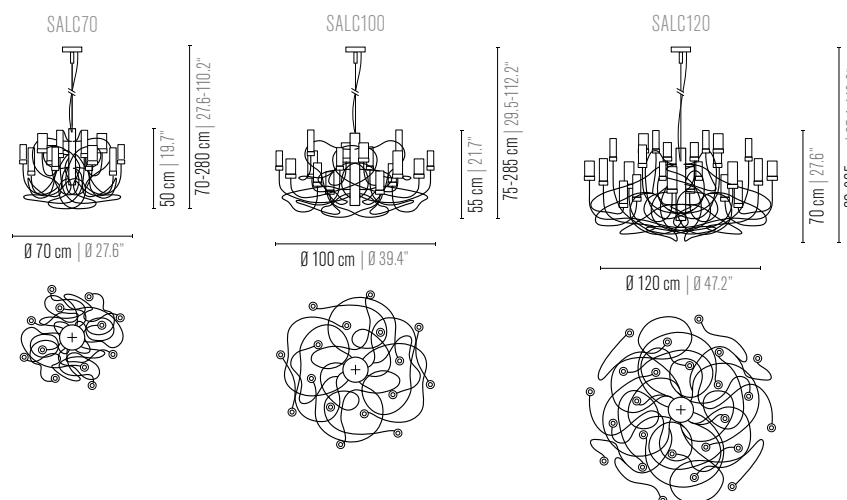

Art. no.	Dimensions	Light source	Weight	Finish
SALC70BL	Ø70xH.50 cm	12x G9	10 kg	black high gloss
SALC70BLM	Ø70xH.50 cm	12x G9	10 kg	black matt
SALC70BDP	Ø70xH.50 cm	12x G9	10 kg	bronze dark patina
SALC70BRBUR	Ø70xH.50 cm	12x G9	10 kg	brass burnished
SALC70BRAC	Ø70xH.50 cm	12x G9	10 kg	brass aged colour
SALC70GSF	Ø70xH.50 cm	12x G9	10 kg	gold satin
SALC70SSF	Ø70xH.50 cm	12x G9	10 kg	silver satin
SALC100BL	Ø100xH.55 cm	16x G9	21 kg	black high gloss
SALC100BLM	Ø100xH.55 cm	16x G9	21 kg	black matt
SALC100BDP	Ø100xH.55 cm	16x G9	21 kg	bronze dark patina
SALC100BRBUR	Ø100xH.55 cm	16x G9	21 kg	brass burnished
SALC100BRAC	Ø100xH.55 cm	16x G9	21 kg	brass aged colour
SALC100GSF	Ø100xH.55 cm	16x G9	21 kg	gold satin
SALC100SSF	Ø100xH.55 cm	16x G9	21 kg	silver satin
SALC120BL	Ø120xH.70 cm	24x G9	31 kg	black high gloss
SALC120BLM	Ø120xH.70 cm	24x G9	31 kg	black matt
SALC120BDP	Ø120xH.70 cm	24x G9	31 kg	bronze dark patina
SALC120BRBUR	Ø120xH.70 cm	24x G9	31 kg	brass burnished
SALC120BRAC	Ø120xH.70 cm	24x G9	31 kg	brass aged colour
SALC120GSF	Ø120xH.70 cm	24x G9	31 kg	gold satin
SALC120SSF	Ø120xH.70 cm	24x G9	31 kg	silver satin

Details of the model

All chandeliers are supplied with a Ø12 cm (4.7 in) ceiling cover HS-1, 250 cm (98.4 in) of steel cable, and 350 cm (137.8 in) of electric cable. The total drop can be easily adjusted on-site.

Details of the collection

The standard light bulbs are: G9 for 220-240V | G9-U for 110-120V versions - check BvE specifications.

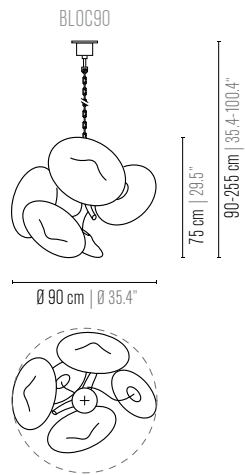

Art. no.	Dimensions	Light source	Weight	Finish
BLOC90BDP-GLGB	Ø90xH.75 cm	5x E14	18 kg	bronze dark patina, glass in grey shades
BLOC90BDP-GLSAT	Ø90xH.75 cm	5x E14	18 kg	bronze dark patina, glass satin
BLOC90BRAC-GLGB	Ø90xH.75 cm	5x E14	18 kg	brass aged colour, glass in grey shades
BLOC90BRAC-GLSAT	Ø90xH.75 cm	5x E14	18 kg	brass aged colour, glass satin
BLOC90GSF-GLGB	Ø90xH.75 cm	5x E14	18 kg	gold satin, glass in grey shades
BLOC90GSF-GLSAT	Ø90xH.75 cm	5x E14	18 kg	gold satin, glass satin
BLOC90SSF-GLGB	Ø90xH.75 cm	5x E14	18 kg	silver satin, glass in grey shades
BLOC90SSF-GLSAT	Ø90xH.75 cm	5x E14	18 kg	silver satin, glass satin

Details of the models

All chandeliers are supplied with a Ø10 cm (3.94 in) cylindrical ceiling cover A-2, Ø16 cm (6.3 in) mounting plate, 170 cm (66.9 in) of chain, and 350 cm (137.8 in) of electrical cable to be woven into the chain. The total drop can be easily adjusted on-site.

Details of the collection

The standard light bulbs are: globe E14-G1 for 220-240V | E12-G1 for 110-120V versions - check BvE specifications.

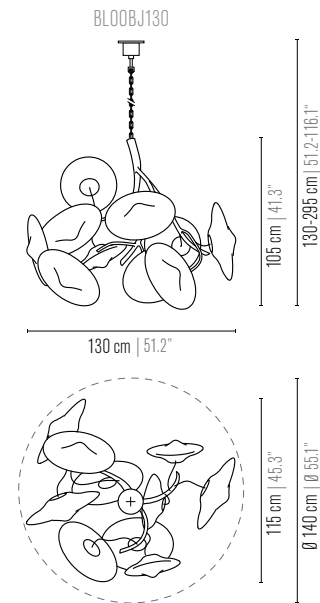

Art. no.	Dimensions	Light source	Weight	Finish
BLOOBJ130BDP-GLGB	L.130xW.115xH.105 cm	10x E14	34 kg	bronze dark patina, glass in grey shades
BLOOBJ130BDP-GLSAT	L.130xW.115xH.105 cm	10x E14	34 kg	bronze dark patina, glass satin
BLOOBJ130BRAC-GLGB	L.130xW.115xH.105 cm	10x E14	34 kg	brass aged colour, glass in grey shades
BLOOBJ130BRAC-GLSAT	L.130xW.115xH.105 cm	10x E14	34 kg	brass aged colour, glass satin
BLOOBJ130GSF-GLGB	L.130xW.115xH.105 cm	10x E14	34 kg	gold satin, glass in grey shades
BLOOBJ130GSF-GLSAT	L.130xW.115xH.105 cm	10x E14	34 kg	gold satin, glass satin
BLOOBJ130SSF-GLGB	L.130xW.115xH.105 cm	10x E14	34 kg	silver satin, glass in grey shades
BLOOBJ130SSF-GLSAT	L.130xW.115xH.105 cm	10x E14	34 kg	silver satin, glass satin

Details of the models

All chandeliers are supplied with a Ø10 cm (3.94 in) cylindrical ceiling cover A-2, Ø16 cm (6.3 in) mounting plate, 170 cm (66.9 in) of chain, and 350 cm (137.8 in) of electrical cable to be woven into the chain. The total drop can be easily adjusted on-site.

Details of the collection

The standard light bulbs are: globe E14-G1 for 220-240V | E12-G1 for 110-120V versions - check BvE specifications.

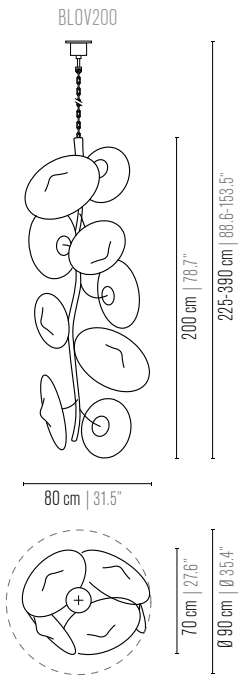

Art. no.	Dimensions	Light source	Weight	Finish
BLOV200BDP-GLGB	L.80xW.70xH.200 cm	10x E14	34 kg	bronze dark patina, glass in grey shades
BLOV200BDP-GLSAT	L.80xW.70xH.200 cm	10x E14	34 kg	bronze dark patina, glass satin
BLOV200BRAC-GLGB	L.80xW.70xH.200 cm	10x E14	34 kg	brass aged colour, glass in grey shades
BLOV200BRAC-GLSAT	L.80xW.70xH.200 cm	10x E14	34 kg	brass aged colour, glass satin
BLOV200GSF-GLGB	L.80xW.70xH.200 cm	10x E14	34 kg	gold satin, glass in grey shades
BLOV200GSF-GLSAT	L.80xW.70xH.200 cm	10x E14	34 kg	gold satin, glass satin
BLOV200SSF-GLGB	L.80xW.70xH.200 cm	10x E14	34 kg	silver satin, glass in grey shades
BLOV200SSF-GLSAT	L.80xW.70xH.200 cm	10x E14	34 kg	silver satin, glass satin

Details of the models

All chandeliers are supplied with a Ø10 cm (3.94 in) cylindrical ceiling cover A-2, Ø16 cm (6.3 in) mounting plate, 170 cm (66.9 in) of chain, and 350 cm (137.8 in) of electrical cable to be woven into the chain. The total drop can be easily adjusted on-site.

Details of the collection

The standard light bulbs are: globe E14-G1 for 220-240V | E12-G1 for 110-120V versions - check BvE specifications.

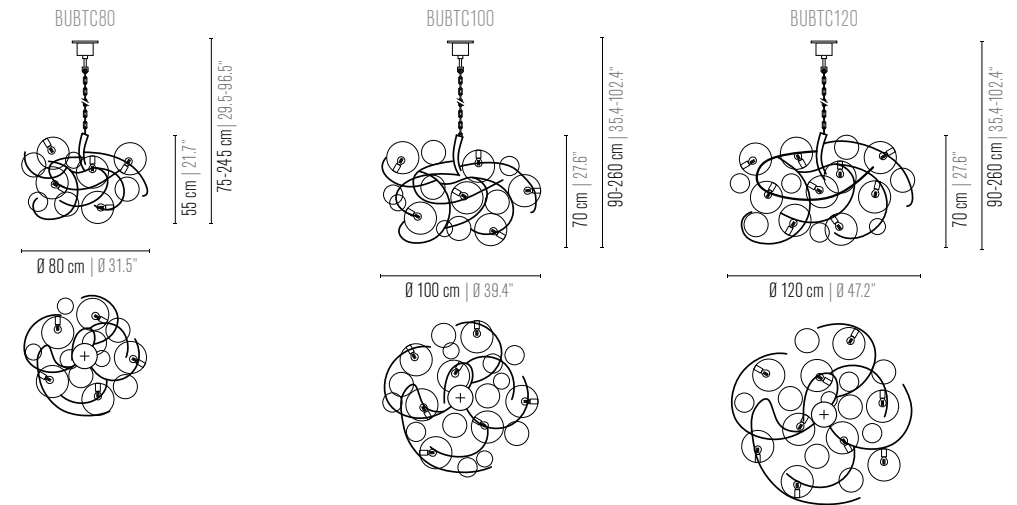

Art. no.	Dimensions	Light source	Weight	Finish
BUBTC80BDP	Ø80xH.55 cm	5x E14	19 kg	bronze dark patina
BUBTC80BRAC	Ø80xH.55 cm	5x E14	19 kg	brass aged colour
BUBTC80GSF	Ø80xH.55 cm	5x E14	19 kg	gold satin
BUBTC80SSF	Ø80xH.55 cm	5x E14	19 kg	silver satin
BUBTC100BDP	Ø100xH.70 cm	7x E14	22 kg	bronze dark patina
BUBTC100BRAC	Ø100xH.70 cm	7x E14	22 kg	brass aged colour
BUBTC100GSF	Ø100xH.70 cm	7x E14	22 kg	gold satin
BUBTC100SSF	Ø100xH.70 cm	7x E14	22 kg	silver satin
BUBTC120BDP	Ø120xH.70 cm	9x E14	28 kg	bronze dark patina
BUBTC120BRAC	Ø120xH.70 cm	9x E14	28 kg	brass aged colour
BUBTC120GSF	Ø120xH.70 cm	9x E14	28 kg	gold satin
BUBTC120SSF	Ø120xH.70 cm	9x E14	28 kg	silver satin

Details of the models

All chandeliers are supplied with a Ø10 cm (3.94 in) cylindrical ceiling cover A-2, Ø16 cm (6.3 in) mounting plate, 170 cm (66.9 in) of chain, and 350 cm (137.8 in) of electrical cable to be woven into the chain. The total drop can be easily adjusted on-site.

Details of the collection

By default, the glass spheres for Bubbles Twilight are a mix of glass in grey shades and clear. The standard light bulbs are: globe E14-G1 for 220-240V | E12-G1 for 110-120V versions - check BvE specifications.

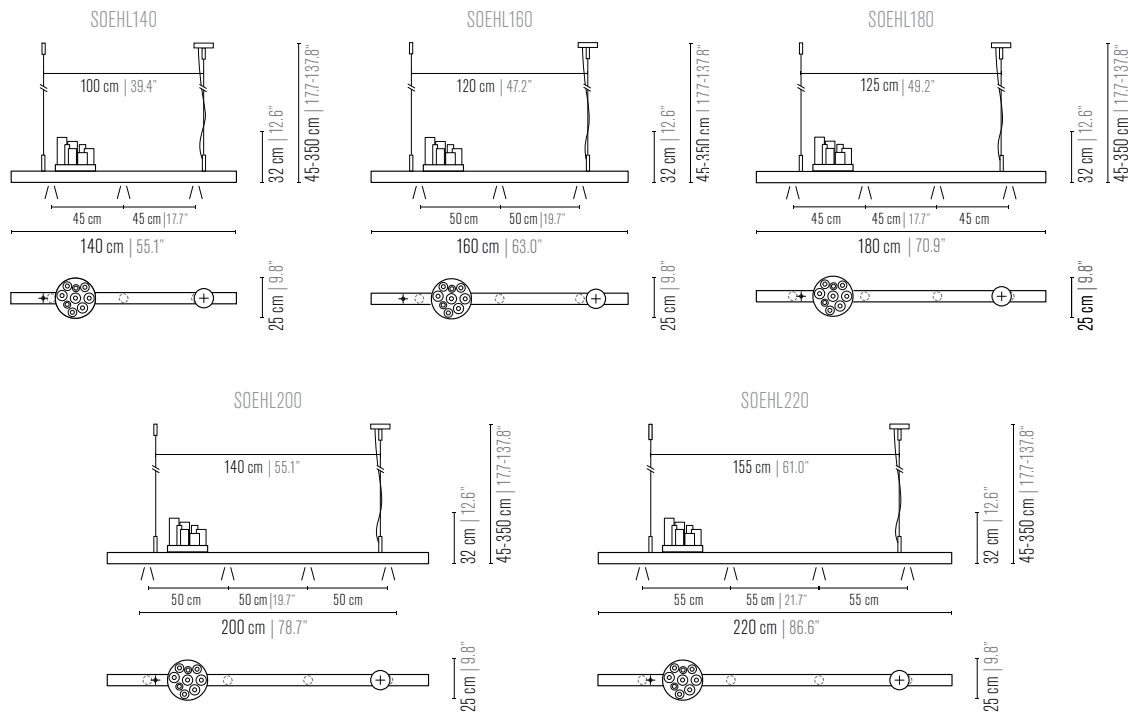

Art. no.	Dimensions	Light source	Weight	Finish
SOEHL140BLM-TRN	L.140xW.25xH.32 cm	3x GU10 spot downlight + 9x G9	14 kg	black matt, nickel tray
SOEHL140BLM-TRGC	L.140xW.25xH.32 cm	3x GU10 spot downlight + 9x G9	14 kg	black matt, gold colour tray
SOEHL160BLM-TRN	L.160xW.25xH.32 cm	3x GU10 spot downlight + 9x G9	15 kg	black matt, nickel tray
SOEHL160BLM-TRGC	L.160xW.25xH.32 cm	3x GU10 spot downlight + 9x G9	15 kg	black matt, gold colour tray
SOEHL180BLM-TRN	L.180xW.25xH.32 cm	4x GU10 spot downlight + 9x G9	17 kg	black matt, nickel tray
SOEHL180BLM-TRGC	L.180xW.25xH.32 cm	4x GU10 spot downlight + 9x G9	17 kg	black matt, gold colour tray
SOEHL200BLM-TRN	L.200xW.25xH.32 cm	4x GU10 spot downlight + 9x G9	18 kg	black matt, nickel tray
SOEHL200BLM-TRGC	L.200xW.25xH.32 cm	4x GU10 spot downlight + 9x G9	18 kg	black matt, gold colour tray
SOEHL220BLM-TRN	L.220xW.25xH.32 cm	4x GU10 spot downlight + 9x G9	19 kg	black matt, nickel tray
SOEHL220BLM-TRGC	L.220xW.25xH.32 cm	4x GU10 spot downlight + 9x G9	19 kg	black matt, gold colour tray

Details of the model

All long lamps are supplied with \varnothing 12 cm (4.7 in) and \varnothing 2 cm (0.8 in) ceiling covers HL-1, 250 cm (98.4 in) of double steel cable, and 350 cm (137.8 in) of electric cable. The total drop can be easily adjusted on-site. The spot downlights are on a separate circuit. Tabletop enlightened by hidden 3-4x GU10 7,5 watt/ 390 - 455 lm downlights.

Details of the collection

The Soirée candles tray can be produced in various finishes on request.

The standard light bulbs are: globe GU10-B and G9 for 220-240V | GU10-B-U and G9-U for 110-120V versions - check BvE specifications.

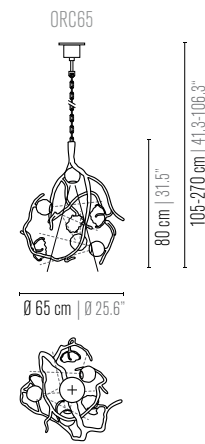

Art. no.	Dimensions	Light source	Weight	Finish
ORC65BDP-AM	\varnothing 65xH.80 cm	4x GU10 spot downlight	12 kg	bronze dark patina with amethyst
ORC65BDP-PYR	\varnothing 65xH.80 cm	4x GU10 spot downlight	12 kg	bronze dark patina with pyrite
ORC65BDP-MAL	\varnothing 65xH.80 cm	4x GU10 spot downlight	12 kg	bronze dark patina with malachite
ORC65BDP-NYMR-R	\varnothing 65xH.80 cm	4x GU10 spot downlight	12 kg	bronze dark patina with Nymphenburg rose - LIMITED EDITION

Details of the models

All chandeliers are supplied with a \varnothing 10 cm (3.94 in) cylindrical ceiling cover A-2, \varnothing 16 cm (6.3 in) mounting plate, 170 cm (66.9 in) of chain, and 350 cm (137.8 in) of electrical cable to be woven into the chain. The total drop can be easily adjusted on-site.

Each semi-precious stone is enlightened by a GU10 spotlight.

The functional light is from the centre down on the tabletop - 1x GU10 7,5 watt/ 390 - 455 lm downlight.

Options for Orpheus

The semi-precious Orpheus stones vary in size, shape, colour, and appearance. Due to the rarity of these semi-precious stones and minerals, availability must be confirmed before an order can be finalised.

All semi-precious stones and minerals are selected with the utmost care by Brand van Egmond. They arrive in pure, untouched and unpolished form in our hands, just as Mother Earth offers them. These are hallmarks of authenticity and should be embraced as the beauty of natural imperfection.



Details of the collection

The standard light bulbs are: GU10-B for 220-240V | GU10-B-U for 110-120V versions - check BvE specifications.

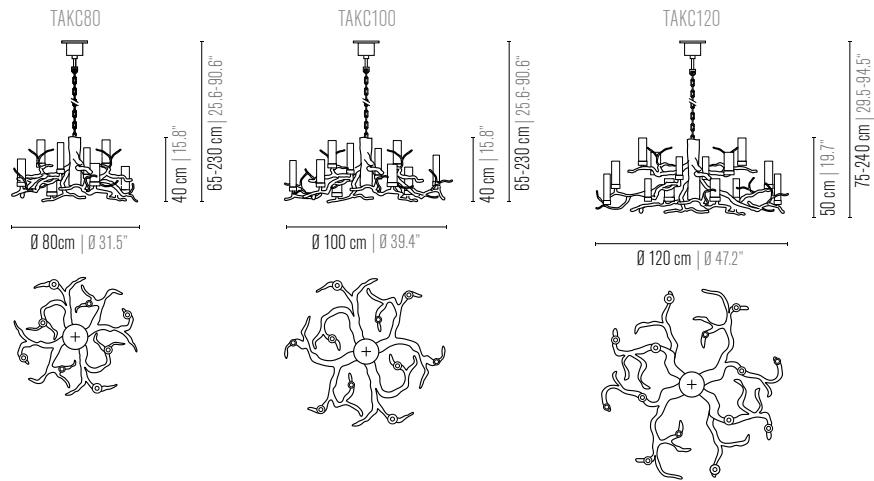

Art. no.	Dimensions	Light source	Weight	Finish
TAKCC80BDP	Ø80xH.40 cm	8x G9	13 kg	bronze dark patina
TAKCC80N	Ø80xH.40 cm	8x G9	13 kg	nickel
TAKCC100BDP	Ø100xH.40 cm	10x G9	15 kg	bronze dark patina
TAKCC100N	Ø100xH.40 cm	10x G9	15 kg	nickel
TAKCC120BDP	Ø120xH.50 cm	14x G9	18 kg	bronze dark patina
TAKCC120N	Ø120xH.50 cm	14x G9	18 kg	nickel

Details of the models

All chandeliers are supplied with a Ø10 cm (3.94 in) cylindrical ceiling cover A-2, Ø16 cm (6.3 in) mounting plate, 170 cm (66.9 in) of chain, and 350 cm (137.8 in) of electrical cable to be woven into the chain. The total drop can be easily adjusted on-site.

Details of the collection

The standard light bulbs are: globe G-9 for 220-240V | G9-U for 110-120V versions - check BvE specifications.

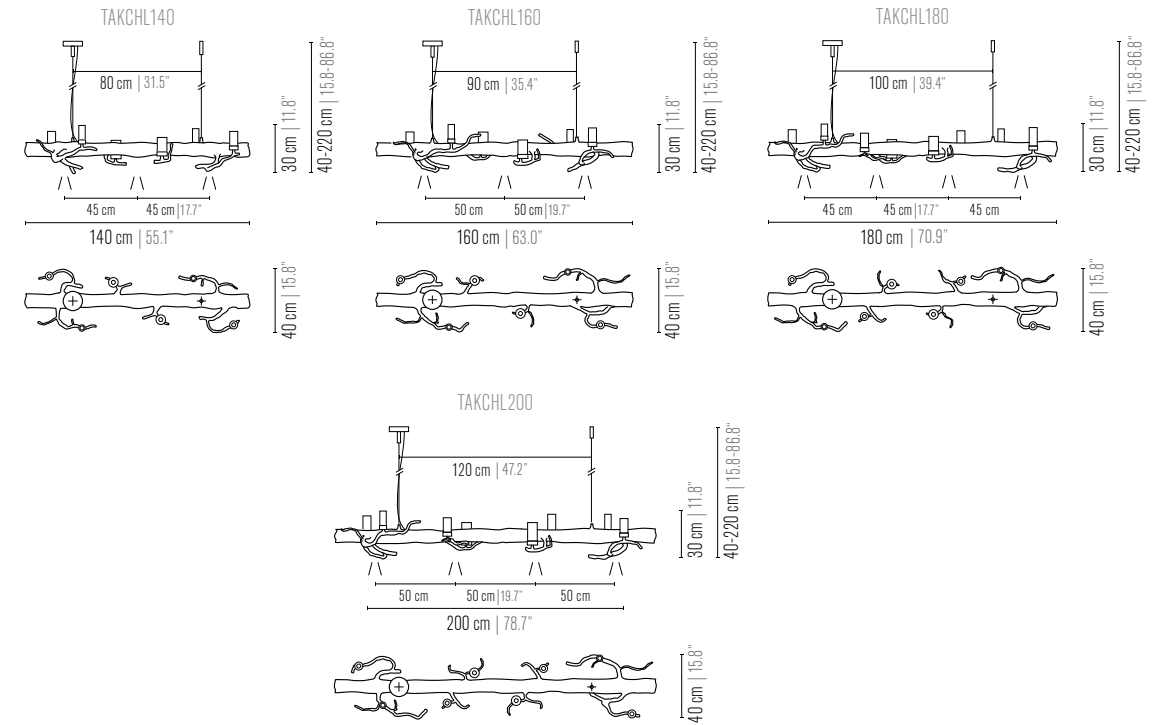

Art. no.	Dimensions	Light source	Weight	Finish
TAKCHL140BDP	L.140xW.40xH.30 cm	3x GU10 spot downlight + 6x G9	15 kg	bronze dark patina
TAKCHL140N	L.140xW.40xH.30 cm	3x GU10 spot downlight + 6x G9	15 kg	nickel
TAKCHL160BDP	L.160xW.40xH.30 cm	3x GU10 spot downlight + 6x G9	17 kg	bronze dark patina
TAKCHL160N	L.160xW.40xH.30 cm	3x GU10 spot downlight + 6x G9	17 kg	nickel
TAKCHL180BDP	L.180xW.40xH.30 cm	4x GU10 spot downlight + 8x G9	20 kg	bronze dark patina
TAKCHL180N	L.180xW.40xH.30 cm	4x GU10 spot downlight + 8x G9	20 kg	nickel
TAKCHL200BDP	L.200xW.40xH.30 cm	4x GU10 spot downlight + 8x G9	22 kg	bronze dark patina
TAKCHL200N	L.200xW.40xH.30 cm	4x GU10 spot downlight + 8x G9	22 kg	nickel

Details of the model

All long lamps are supplied with Ø12 cm (4.7 in) and Ø2 cm (0.8 in) ceiling covers HL-1, 250 cm (98.4 in) of double steel cable, and 350 cm (137.8 in) of electric cable. The total drop can be easily adjusted on-site. The spot downlights are on a separate circuit. Tabletop enlightened by hidden 3-4x GU10 7,5 watt/ 390 - 455 lm downlights.

Details of the collection

The standard light bulbs are: globe GU10-B and G9 for 220-240V | GU10-B-U and G9-U for 110-120V versions - check BvE specifications.

General Terms and Conditions



1. Applicability of terms and Conditions of Sales

- 1.1 These general conditions of sales and delivery shall apply to all offers, quotes, deliveries, services and agreements of Brand van Egmond B.V. ("BRAND VAN EGMOND").
- 1.2 All orders are accepted and executed by BRAND VAN EGMOND subject to and in accordance with the following conditions of sales which override and exclude any other terms stipulated or incorporated or referred to by the customer during any negotiations or in any course of dealing between BRAND VAN EGMOND and the customer.
- 1.3 No variation or deviation to these conditions of sales is permitted unless expressly authorised in writing by a director of BRAND VAN EGMOND.

2. Quotations and orders

- 2.1 Subject to the terms contained in this section, any quotation provided by BRAND VAN EGMOND will be without engagement.
- 2.2 Although BRAND VAN EGMOND strives to provide accurate product and pricing information, errors or misprints may occur. BRAND VAN EGMOND cannot confirm the price of a product until after the customer requests the quotation. Notwithstanding anything contained in this section, in the event that a product is listed at an incorrect price or with incorrect information due to an error in pricing or product information, BRAND VAN EGMOND shall have the right, at its sole discretion, to refuse or cancel any orders placed for that product. In the event that a product is priced in error or a product information error occurs, BRAND VAN EGMOND may, at its sole discretion, either contact the customer for instructions, cancel the order and notify the customer of such cancellation, and/or correct the error on its web site/pricelist, any without liability.
- 2.3 Orders are not binding on BRAND VAN EGMOND until accepted and confirmed by BRAND VAN EGMOND. BRAND VAN EGMOND's acceptance of an order is evidenced in writing including return e-mail from BRAND VAN EGMOND indicating that customer's order has been accepted.
- 2.4 Changes of orders will be accepted up to 3 (three) days only from the order confirmation.
- 2.5 The cancellation of a confirmed order is valid only if it as accepted in writing by BRAND VAN EGMOND. Expenses due to cancellation will be charged.

3. Prices

- 3.1 Prices for products are in EUR and exclusive of VAT, unless otherwise indicated.
- 3.2 BRAND VAN EGMOND reserves the right to increase prices after execution of the agreement and without notice at any time in the event that the manufacturing prices of BRAND VAN EGMOND increase.
- 3.3 Unless indicated otherwise in writing by BRAND VAN EGMOND, the prices are based on delivery on the basis of EXW (Ex Works), Naarden, The Netherlands (according to the latest version of the ICC Incoterms®).

4. Payment

- 4.1 Unless credit terms have been agreed to in writing by BRAND VAN EGMOND, customer shall pay invoices within thirty (30) days from the date of the invoices without any deductions or set-off whatsoever.
- 4.2 If payment is not received by BRAND VAN EGMOND by the due date, the customer shall pay a financing charge of 2% of the capital sum for each month or portion thereof during which payment remains outstanding, until payment is made in full.
- 4.3 BRAND VAN EGMOND reserves the right to demand payment up front or to demand security for the payment of the invoices before commencing the production and/or delivery of the products.
- 4.4 If the customer fails to make payment by the due date or fails to provide security without prejudice to any other right or remedy, and without prior notice of default, BRAND VAN EGMOND shall be entitled to: i. cancel the order or suspend any further deliveries; and ii. appropriate any payment made by the customer to such of the products (or the products supplied under any other contract) as BRAND VAN EGMOND may think fit.
- 4.5 All expenses in connection with the recovery of the amounts payable and not paid in time by BRAND VAN EGMOND shall be for the account of the customer. The extrajudicial expenses shall be at least 15% of the amount due, at a minimum of Euro 750, and shall already be payable and claimable as soon as the claim is passed out of hand for collection.

5. Accounts

- 5.1 A customer wishing to open a credit account must furnish such information as requested by BRAND VAN EGMOND and BRAND VAN EGMOND will make a search with a credit reference agency. BRAND VAN EGMOND reserves the right in its absolute discretion to grant, refuse or discontinue any credit facilities or reduce or suspend any credit limit at any time.

6. Product availability; special orders

- 6.1 Product availability may be limited. Products may not be available for immediate delivery. BRAND VAN EGMOND reserves the right, without liability or prior notice, to revise or cease to make available any or all products. All articles shall be executed in standard design.
- 6.2 For an order of deviating models or colours or special requests a surcharge shall be made, this after prior written consultation. All special orders are, unless agreed to otherwise in writing, paid for by the customer upfront.

7. Delivery

- 7.1 Unless agreed otherwise in writing delivery shall take place EXW (Ex Works) Naarden, the Netherlands, according to the latest version of the ICC Incoterms®.
- 7.2 BRAND VAN EGMOND will use reasonable endeavours to meet delivery estimates but in no circumstances shall it be liable to compensate the customer for non-delivery or late delivery.
- 7.3 BRAND VAN EGMOND reserves the right to deliver by instalments or in parts. Failure to meet a delivery date where delivery is by instalments shall not preclude BRAND VAN EGMOND's right to make further deliveries by instalments under the relevant contract.
- 7.4 The customer may request delivery by instalments for a maximum period of 12 months from the date of order.
- 7.5 The risk for the goods to be delivered shall pass to the customer from the moment that they are placed at the disposal of the customer at the premises of BRAND VAN EGMOND unless agreed to otherwise in writing. Any assistance by BRAND VAN EGMOND with the loading of the goods on any means of transportation shall be for the risk of the customer.
- 7.6 If delivery of the goods is refused by the customer, without prejudice to the provisions of article 9, the risk of the goods shall pass to the customer at once and BRAND VAN EGMOND can immediately claim payment. BRAND VAN EGMOND shall keep the goods at the customer's risks and expense until

further notice.

- 7.7 If the customer continues to default after being summoned BRAND VAN EGMOND shall be entitled to dispose of the goods or to give them another destination. Any proceeds shall be credited to the customer with deduction of all expenses coming for his account, without prejudice to BRAND VAN EGMOND's right to full payment of the agreed price.

8. Inspection, defects and non-delivery, returns

- 8.1 The customer must inspect the products at the moment of delivery. BRAND VAN EGMOND shall not be liable for any defects in the products unless written notice with a statement of reasons is given to BRAND VAN EGMOND within seven (7) days of receipt. If complaints have not been made in the above mentioned manner and within the aforementioned period of seven (7) days, the delivery shall be considered unconditionally accepted.
- 8.2 The quantity of any consignment of products as recorded by BRAND VAN EGMOND upon despatch from BRAND VAN EGMOND's place of business shall be conclusive evidence of the quantity received by the customer on delivery, unless the customer can provide conclusive evidence to the contrary.
- 8.3 Customary deviations shall not be reasons for complaint. The photos on this web site, in our catalogue and brochures are provided to assist you in choosing the right product. These photos are meant to be samples only and are not intended to provide a perfect match to the actual product color. Colors and photo size may vary based upon your screen resolution and other computer settings outside of our control. The photo may differ from the actual product due to reproduction limitations of the photograph and limitations of viewing photos at different resolutions, hue, brightness, contrast, and other screen variations. Therefore, Brand van Egmond shall not be held responsible for any variation between the photos on this website/catalogue and the actual products you receive, including but not limited to: Color variation, grain variation, color change, and character variation. Small irregularities in shape, finishes, and surfaces are hallmarks of craftsmanship and should not be considered defects but as a sign of the unique authenticity of our handwork and cherished as such.
- 8.4 Any liability of BRAND VAN EGMOND for non-delivery or defective products shall to BRAND VAN EGMOND's discretion be limited to replacing, repairing or making up the products within a reasonable time.
- 8.5 No order can be cancelled or accepted without previous written agreement of BRAND VAN EGMOND.
- 8.6 Products may not be returned without BRAND VAN EGMOND's permission. If BRAND VAN EGMOND agrees to take the Products back, the customer shall obtain a return merchandise authorisation number (RMA number). Any products returned must be provided with the RMA number by the customer and be received by BRAND VAN EGMOND within seven (7) days of delivery and must be complete, undamaged and in original packaging. Products returned after seven (7) days as unwanted or incorrectly ordered will be accepted at the discretion of BRAND VAN EGMOND and will be subject to a restocking fee representing 30% of the invoice value of the products.
- 8.7 Certain products - such as products specially designed or manufactured for the customer - are excluded from any return. The customer is responsible for returning products to BRAND VAN EGMOND and for providing proof of delivery of such return.
- 8.8 Products will be returned at the customer's expense.

9. Retention of title

- 9.1 Ownership of the products shall not pass to the customer until BRAND VAN EGMOND has received in full (in cash or cleared funds) all sums due in respect of the products.
- 9.2 The customer shall not be entitled to alienate or encumber the products in any way as long as full payment has not been made to BRAND VAN EGMOND, except where and in so far as the normal conduct of business is concerned. The customer shall be obliged to pledge to BRAND VAN EGMOND any claims on third parties resulting from this, on pain of a fine to the amount of 50% of the invoice amount for the goods supplied, with a minimum of € 2.250,=.
- 9.3 If payment is not received in full by the due date, or the customer passes a resolution for winding up or a court shall make an order to that effect, or a receiver is appointed over any assets or the undertaking of the customer or an execution or distress is levied against the customer, BRAND VAN EGMOND shall be entitled, without previous notice, to retake possession of the products and for that purpose to enter upon any premises occupied or owned by the customer.

10. Performance and fitness for purpose

- 10.1 Unless any performance figures, tolerances or characteristics have been specifically and expressly warranted by a director of BRAND VAN EGMOND in writing, BRAND VAN EGMOND accepts no liability for any failure of the products to obtain such figures.
- 10.2 The responsibility for ensuring that products are sufficient and suitable for a particular purpose is the customer's, unless specifically stated in writing by a director of BRAND VAN EGMOND.
- 10.3 Any advice or recommendation given by an employee of BRAND VAN EGMOND, which is not confirmed in writing by a director of BRAND VAN EGMOND, is acted on entirely at the customer's risk and BRAND VAN EGMOND and its employees shall not be liable for any such advice or recommendation which is not so confirmed.

11. Guarantee

- 11.1 Each product has been manufactured and packaged to meet BRAND VAN EGMOND's high standards. Any defects which, under proper use, appear in the products within a period of twelve (12) months (unless otherwise stated by BRAND VAN EGMOND) and which are due to faulty materials, workmanship or design will be made good by BRAND VAN EGMOND either by repair, or at BRAND VAN EGMOND's option, replacement (which is BRAND VAN EGMOND's sole obligation and the customer's sole remedy).
- 11.2 BRAND VAN EGMOND's guarantee is accepted by the customer in substitution for all express or implied representations, conditions or warranties, statutory or otherwise, as to the satisfactory quality, fitness for purpose or performance of the products (or any materials used in connection therewith) or the standard of workmanship of any services provided, and all such representations, conditions and warranties are excluded.
- 11.3 BRAND VAN EGMOND shall not be liable for defective products if the defect arises because the customer alters or repairs such products without the written consent of BRAND VAN EGMOND or because the customer did not follow the manufacturers' instructions for storage, usage, installation, use or maintenance of the products.
- 11.4 Any products replaced or repaired under this paragraph will be guaranteed on these terms for any unexpired portion of the guarantee given on the original products.

12. Liability

- 12.1 These conditions of sales set out the entire liability of BRAND VAN EGMOND to the customer in respect of the products and shall be in lieu and to the exclusion of all other warranties, conditions, and other terms implied by statute or common law save for any implied terms which by law cannot be excluded.
- 12.2 Nothing in these conditions of sale excludes or limits the liability of BRAND VAN EGMOND for death or personal injury caused by BRAND VAN EGMOND's negligence or fraudulent misrepresentation.
- 12.3 BRAND VAN EGMOND's total liability in contract, tort (including negligence or breach of statutory duty), misrepresentation or otherwise shall be limited to repairing, replacing or at BRAND VAN EGMOND's option refunding monies already paid in respect of the products.
- 12.4 BRAND VAN EGMOND shall not be liable to the customer for any indirect or consequential loss or damage (whether for loss of profit, loss of business, loss of goodwill or otherwise) costs, expenses or other claims for consequential compensation whatsoever (whether caused by the negligence of BRAND VAN EGMOND, its employees, agents or subcontractors) which arise out of or in connection with any contract.
- 12.5 BRAND VAN EGMOND shall not be liable for damage if the customer has not held BRAND VAN EGMOND liable for the damage by registered letter within a reasonable time after becoming aware of the cause of damage, but not later than thirty (30) days after becoming aware of the damage.
- 12.6 All stipulations concerning the exclusion or limitation of BRAND VAN EGMOND's liability for and concerning BRAND VAN EGMOND's indemnity against claims of third parties have also been made for the benefit of the persons who are employed by BRAND VAN EGMOND as well as third parties for whose actions or omissions BRAND VAN EGMOND can be liable.

13. Termination

- 13.1 If the customer is in default with timely payment or fulfilment of other obligations towards BRAND VAN EGMOND, BRAND VAN EGMOND shall remain entitled, without any notice of default, to consider the agreement rescinded, without prejudice to BRAND VAN EGMOND's right to full compensation of damage suffered and to be suffered and any further rights.
- 13.2 The power to rescind the agreement on the strength of article 13.1 shall also be due to BRAND VAN EGMOND if BRAND VAN EGMOND finds that the customer has filed an application for a provisional moratorium, is being declared bankrupt, goods of the customer are being attached before judgment or under an execution, or his debts are being liquidated.
- 13.3 The damage suffered and yet to be suffered as referred to in article 13.1. shall be at least 10% of the agreed price, without BRAND VAN EGMOND being obliged to prove that this damage has been or will be suffered.
- 13.4 In the event of rescission on the strength of article 13 any credit that BRAND VAN EGMOND has granted the customer shall be claimable immediately without further notice of default being required.

14. Intellectual property rights

- 14.1 The only BRAND VAN EGMOND trademarks and/or other rights of intellectual property that the customer may display to advertise and sell the products, shall be those trademarks and/or intellectual property rights under which the products are sold by BRAND VAN EGMOND to the customer hereunder, or such other trademarks expressly authorised by BRAND VAN EGMOND (hereinafter called "the said trademarks").
- 14.2 The customer shall comply with BRAND VAN EGMOND's instructions as to the manner and context in which the said trademarks and the statements to accompany them are displayed.
- 14.3 No trademarks of the products shall be undertaken by the customer or any person on the customer's behalf without BRAND VAN EGMOND's prior written consent nor will the customer alter, obliterate, add to, or otherwise interfere with the said trademarks and/or other intellectual property rights.

15. Export

- 15.1 The customer is responsible at its own expense for obtaining any licence and complying with any export or import regulations in force within the country for which the products are destined.
- 15.2 BRAND VAN EGMOND reserves the right not to supply certain customers or countries and to seek from the customer full details of the end use and final destination of the products.

16. Force majeure

- 16.1 BRAND VAN EGMOND shall not be liable to the customer in any manner or be deemed to be in breach of these conditions of sale because of any delay in performing or any failure to perform any of BRAND VAN EGMOND's obligations under these conditions of sale if the delay or failure was due to any cause beyond BRAND VAN EGMOND's reasonable control (which shall include, but not be limited to government actions, war, fire, explosion, flood, import or export regulations or embargoes, labour disputes or inability to obtain or a delay in obtaining supplies of products or labour, lack and/or interruptions in the means of transport, production equipment or energy supplies).
- 16.2 BRAND VAN EGMOND may, at its option, delay the performance of, or cancel the whole or any part of a contract.

17. General

- 17.1 Any provision of these conditions of sale which is held by any competent authority to be invalid, void, unenforceable or unreasonable (in whole or in part) shall to the extent of such invalidity, voidness, voidability, unenforceability or unreasonableness be deemed severable and the other provisions of these Conditions of Sale and the remainder of such provision shall not be affected.
- 17.2 Failure by BRAND VAN EGMOND to enforce or partially enforce any provision of these conditions of sale will not be constrained as a waiver of any rights under these conditions of sale.

18. Legal construction

- 18.1 All disputes, suits, actions or other legal proceedings arising out of or related to these conditions of sale shall be governed by and interpreted in accordance with the laws of the Netherlands and the customer submits to the jurisdiction of the courts of the Netherlands, but BRAND VAN EGMOND may enforce such contract in any court of competent jurisdiction.
- 18.2 The United Nations Convention on contracts for the International Sale of Goods (1980) is not applicable (CISG).

All rights reserved, copyright© Brand van Egmond B.V. ® 2025.

For all models, texts, layout, and images: Brand van Egmond. Interiors designed by studiodutchdelight.com. Specifications are subject to change without prior notice. Brand van Egmond manufactures exclusive lighting sculptures on a small scale. Because their products are handmade, they may differ from one another. Each product has its own identity and is therefore unique. Each item is labelled with its own number and certificate.

Brand van Egmond reserves the right to change its models from time to time without prior notice. The designs, texts, layout, and pictures included in this brochure are subject to errors and technical changes and are protected by copyright and/or industrial design rights. No part thereof may be made public, reproduced, or amended in any form or manner whatsoever for commercial purposes by third parties, including dealers, retailers, internet shops, and others, without the prior and express written permission of the designer, William Brand.

Colophon

BRAND VAN EGMOND

William Brand

Photography by

SmartStudio / www.smartstudio.pl

Rendering images and Interior design

Studiodutchdelight.com



Brand van Egmond B.V. Nikkelstraat 41, 1411 AH Naarden, The Netherlands

T. +31 (0)35 692 12 59 info@brandvanegmond.com www.brandvanegmond.com

